

# USB-1602HS and USB-1604HS Series

## High-Speed Multifunction DAQ with Synchronous I/O



### Features

- 16-bit high-speed USB devices
- Simultaneous analog, digital, and counter sampling
- Sample rates up to 2 MS/s per channel
- Up to four analog inputs
- Up to two analog outputs
- 16 digital inputs and 16 digital outputs
- One digital trigger input
- Four counter inputs
- Two timer/pulse outputs
- Three quadrature detectors
- Input and output pacer clocks
- External trigger and clock inputs
- SCSI and BNC connectors
- 10 watt external power supply



The USB-1602HS and USB-1604HS Series provides high-speed simultaneous sampling. Signals connect to BNC (front) and SCSI (rear) connectors. The USB-1604HS-2AO is shown here.

### Software

#### Supported Operating Systems

- Windows® 8/7/Vista®/XP 32/64-bit
  - Universal Library™ (UL), ULx for NI LabVIEW™

#### Ready-to-Run Applications

- InstaCal™ (install, configure, and test)
- TracerDAQ® (acquire, view, log, and generate)

#### Supported Programming Environments

- Visual Studio® and Visual Studio .NET, including examples for Visual C++®, Visual C#®, Visual Basic®, and Visual Basic .NET, and other IDEs
- LabVIEW
- DASyLab®
- MATLAB® (Data Acquisition Toolbox™)

### Overview

The USB-1602HS and USB-1604HS Series are high speed devices that can sample analog, digital, and counter inputs simultaneously, while generating analog outputs (when supported) and digital patterns at the same time.

### Analog Input

The USB-1602HS/USB-1602HS-2AO has two analog inputs and the USB-1604HS/USB-1604HS-2AO has four. Each input has a dedicated 16-bit ADC that provides true simultaneous sampling per channel.

| USB-1602HS and USB-1604HS Series Selection Chart |              |                               |               |                       |               |                     |
|--|--------------|-------------------------------|---------------|-----------------------|---------------|---------------------|
| Model  | Analog Input | Sample Rate per Channel (max) | Analog Output | Digital I/O           | Counter Input | Quadrature Encoders |
| USB-1602HS                                       | 2 SE         | 2 MS/s                        | 0             | 16 input<br>16 output | 4             | 3                   |
| USB-1602HS-2AO                                   | 2 SE         | 2 MS/s                        | 2             | 16 input<br>16 output | 4             | 3                   |
| USB-1604HS                                       | 4 SE         | 1.33 MS/s                     | 0             | 16 input<br>16 output | 4             | 3                   |
| USB-1604HS-2AO                                   | 4 SE         | 1.33 MS/s                     | 2             | 16 input<br>16 output | 4             | 3                   |

The input range is software-selectable for  $\pm 10$  V,  $\pm 2.5$  V, or  $\pm 500$  mV. The sample rate is 2 MS/s for the USB-1602HS and USB-1602HS-2AO, and 1.33 MS/s for the USB-1604HS and USB-1604HS-2AO, per channel. Users can pace analog input operations with the internal A/D pacer clock or with an external clock.

### Analog Output

The USB-1602HS-2AO and USB-1604HS-2AO each provide two independent, 16-bit, analog outputs. Each analog output can continuously output a waveform at up to 1 MHz. Users can clock the output operation with the internal output scan clock or with an external clock. The internal analog input clock can pace both the analog input and output simultaneously.

### Digital I/O

The digital I/O lines are configured as 16 inputs and 16 outputs. Users can pace digital operations with the onboard scan clock or with an external source.

### Digital input scanning

Digital input ports can be read synchronously along with analog channels in a scan, or asynchronously before, during, or after an analog input scan. The digital inputs can sustain rates up to 8 MS/s for one channel, when no analog channels are sampled. When analog channels are also sampled, the rate is 1.33 MS/s for the USB-1604HS and USB-1604HS-2AO, and 2 MS/s for the USB-1602HS and USB-1602HS-2AO.

### Digital output scanning

Digital outputs can be updated asynchronously at any time before, during, or after an acquisition.

Users can generate a digital pattern up to 4 MS/s. Digital pattern generation is clocked using the output scan clock. Digital patterns can be generated with waveforms; both are paced by the same selected clock. The onboard clock generates updates ranging from once every 1000 seconds to 1 MHz, independent of the rate.

## General Information

### Counter Input

USB-1602HS and USB-1604HS Series devices have four counters that accept frequency inputs up to 20 MHz. The counter channels can be read as 16-bit or 32-bit counters. The default input type is TTL, rising-edge triggered.

Counters can be used to concurrently monitor time periods, frequencies, pulses, and other event-driven incremental operations. Users can map counter channels to gate a counter, decrement a counter, or latch the current count to the count register. Users can also configure a counter to be gated by another counter input that is mapped as a gate input.

Counters can be read asynchronously under program control, or synchronously as part of an analog or digital scan group.

- When read synchronously, all counters are set to zero at the start of an acquisition.
- When read asynchronously, counters may be cleared on each read, count up continually, or count until the 16-bit or 32-bit limit is reached.

Counter, period, pulse width measurement (PWM), and timing counter modes are supported.

### Quadrature Encoders

Users can connect up to three quadrature encoders to measure linear and rotary position. Encoders with a 16-bit (counter low) or a 32-bit (counter low and counter high) counter, 6 MHz maximum pulse frequency, and X1, X2, and X4 count modes are supported. Each input can be debounced to eliminate noise or false edges, or to switch induced transients.

### Trigger Input

The USB-1602HS and USB-1604HS Series supports hardware and software triggering.

With hardware-based triggers, an output value is compared in hardware to an input level on a specified channel. These hardware-based triggers are supported:

- Analog input hardware
- External digital trigger input (DIG TRIG pin)

With software-based triggers, an analog, digital, or counter reading is checked by the computer in order to detect a trigger event. These software-based triggers are supported:

- Analog software trigger
- Digital pattern
- Counter/totalizer

These software triggers can also be used to stop an acquisition.

### Timer Output

The USB-1602HS and USB-1604HS Series have two timer outputs for generating pulse width waves. The duty cycle and frequency are software-selectable. Timer outputs can be updated asynchronously at any time.

### Clock I/O

The USB-1602HS and USB-1604HS Series have independent input and output pacing clocks.

Users can pace analog, digital, and counter input scans with the internal input clock or an external clock. Analog channels can be paced from 0.75  $\mu$ s to 1000 seconds in 20.83 ns steps. Digital and counter inputs can be paced from 250 ns to 1 second in 20.83 ns steps. The clock rate is 8 MHz maximum for both the internal input clock and external input clock.

Users can pace analog, digital, and timer output operations with the internal input clock, internal output clock, external input clock, or external output clock. The clock rate is 1 MHz maximum for analog output operations, and 8 MHz maximum for digital operations with no analog channels enabled.

### Setpoint Detection

Users can configure a detection setpoint for each analog input channel. Setpoint detection can be used to update an output channel with an input channel value, or to write a specified value to a digital output port, when specified criteria is met. This allows for real-time control based on acquisition data. Setpoint detection criteria is configurable with software.

### Signal Connections

A 68-pin SCSI connector provides connections for all signal I/O except analog inputs.

BNC connectors provide connections for the analog inputs, and alternate connections for the external clock and external digital trigger input.

### Calibration

USB-1602HS and USB-1604HS Series devices are factory-calibrated using a NIST-traceable calibration process. Correction factors for each range are stored on the device at the time of calibration. Specifications are guaranteed for one year. For calibration beyond one year, return the device to the factory for recalibration.

USB-1602HS and USB-1604HS Series devices support field calibration. Field calibration traceability is derived through the onboard reference. Use the InstaCal utility to calibrate the device after it has fully warmed up and immediately before making critical measurements.

# USB-1602HS and USB-1604HS Series

## Functional Block Diagram



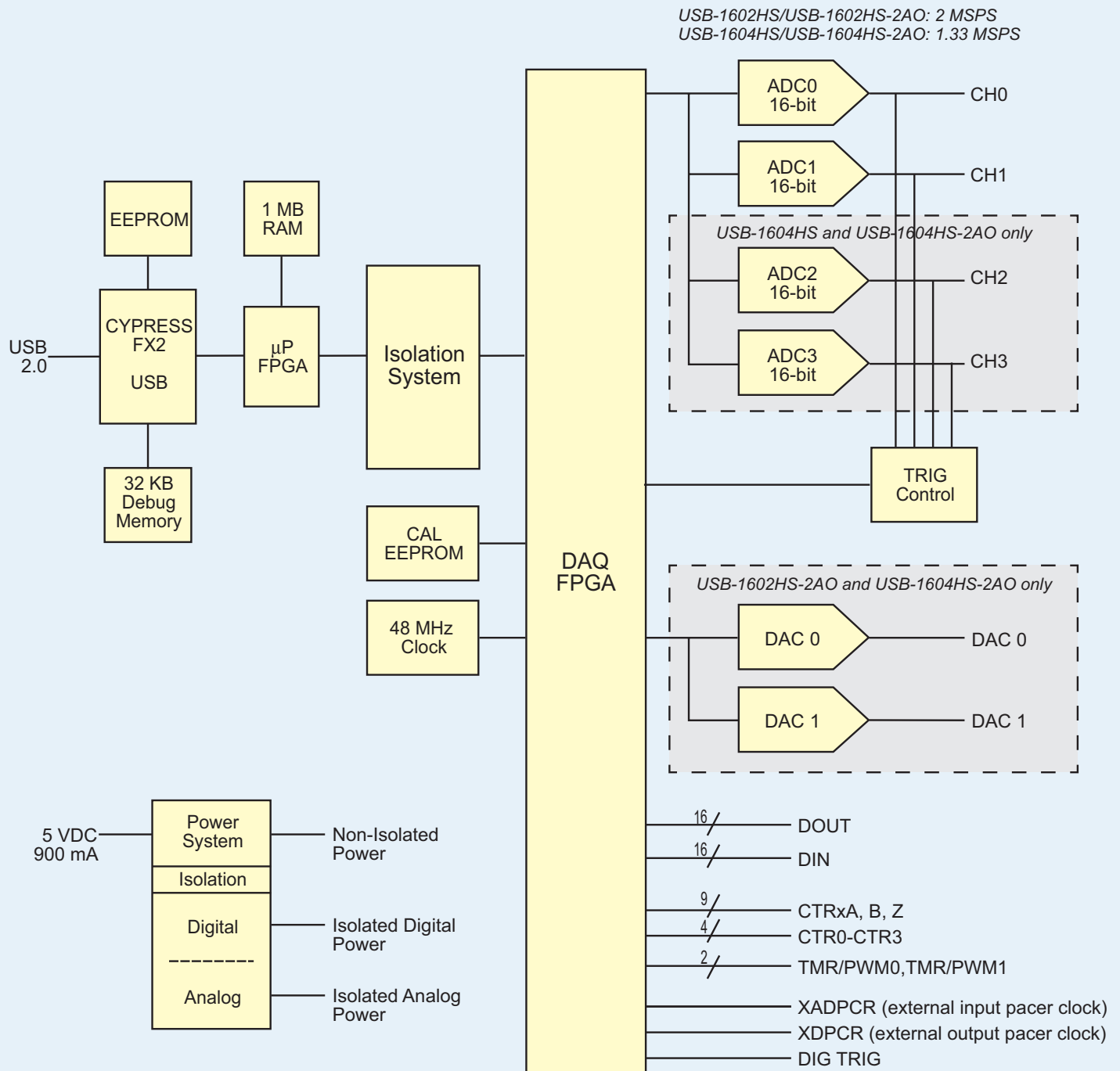

USB-1602HS and USB-1604HS Series Block Diagram

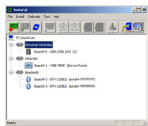
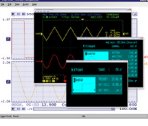
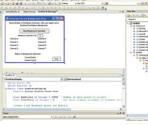
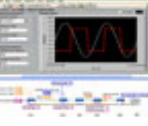

### Software Support

The USB-1602HS is supported by the software in the table below.

| Ready-to-Run Applications                   |   |  |
|---|---|--|
| <a href="#">InstaCal</a>                    |    | <p>An interactive utility that configures and tests MCC hardware. Windows OS</p> <p>InstaCal is included with the free MCC DAQ Software bundle (CD/download).</p>  |
| <a href="#">TracerDAQ and TracerDAQ Pro</a> |    | <p>A virtual strip chart, oscilloscope, function generator, and rate generator applications used to generate, acquire, analyze, display, and export data. Supported features may vary with hardware. The Pro version provides enhanced features. Windows OS</p> <p>TracerDAQ is included with the free MCC DAQ Software bundle (CD/download). TracerDAQ Pro is available as a purchased software download.</p> |
| General-Purpose Programming Support         |   |  |
| <a href="#">Universal Library (UL)</a>      |    | <p>Programming library of function calls for C, C++, VB, C# .Net, and VB .Net using Visual Studio and other IDEs. Windows OS</p> <p>The UL is included with the free MCC DAQ Software bundle (CD/download).</p>  |
| Application-Specific Programming Support    |   |  |
| <a href="#">ULx for NI LabVIEW</a>          |   | <p>A comprehensive library of VIs and example programs for NI LabVIEW that is used to develop custom applications that interact with most MCC devices. Windows OS</p> <p>ULx is included with the free MCC DAQ Software bundle (CD/download).</p>  |
| <a href="#">DASYLab Driver</a>              |  | <p>Icon-based data acquisition, graphics, control, and analysis software that allows users to create complex applications in minimal time without text-based programming.</p> <p>DASYLab is available as a purchased software download. Windows OS</p>   |
| <a href="#">MATLAB Driver</a>               |  | <p>High-level language and interactive environment for numerical computation, visualization, and programming. The Data Acquisition Toolbox, provided by The Mathworks, allows users to acquire data from most MCC PCI and USB devices.</p> <p>Visit <a href="http://www.MathWorks.com">www.MathWorks.com</a> for more information on MATLAB Data Acquisition Toolbox support.</p>                              |

# USB-1602HS and USB-1604HS Series

## Specifications



### Specifications

All specifications are subject to change without notice.  
 Typical for 25 °C unless otherwise specified.  
 All signal names refer to 68 pin SCSI connector, unless otherwise specified.

#### Analog Input

**A/D converter type:** 16-bit successive approximation type  
**Number of channels:**  
 USB-1602HS, USB-1602HS-2AO: 2  
 USB-1604HS, USB-1604HS-2AO: 4  
**Input configuration:** Single-ended  
**Sampling method:** Simultaneous; individual A/D per channel  
**Input ranges:** ±10 V, ±2.5 V, ±500 mV  
**Absolute max input voltage:** ±30 V max (power on), ±20 V max (power off)  
**Input impedance:** 10 MΩ (typ, power on)  
**Input bias current:** < 2 μA  
**Input bandwidth (–3 dB):** 3 MHz, typ  
**Crosstalk** Remaining inputs grounded: 100 dB (at 100 kHz)  
**Pacer sources:** Onboard A/D clock, XAPCR (SCCI connector), or EXT CLK (BNC connector.) Refer to [“Pacing Sources” on page 6](#) for details.  
**Trigger sources and modes:** Refer to [“Trigger Sources” on page 6](#) for details.  
**Sample rate:** Software-selectable.  
 USB-1602HS, USB-1602HS-2AO: 0.01 S/s to 2 MS/s each channel  
 USB-1604HS, USB-1604HS-2AO: 0.01 S/s to 1.33 MS/s each channel  
**Resolution:** 16-bits  
**INL (integral non-linearity):** ±2.0 LSB  
**DNL (differential non-linearity):** ±1.0 LSB

| Calibrated Accuracy |               |
|---------------------|---------------|
| Range               | Accuracy (mV) |
| ±10 V               | ±1            |
| ±2.5 V              | ±0.5          |
| ±500 mV             | ±0.15         |

| Noise Performance |        |                    |
|-------------------|--------|--------------------|
| Range             | Counts | LSB <sub>rms</sub> |
| ±10 V             | 8      | 1.3                |
| ±2.5 V            | 11     | 1.6                |
| ±500 mV           | 17     | 2.5                |

Noise distribution is determined by gathering 50,000 samples with inputs tied to ground at the BNC connectors. Samples are gathered at the max specified rate.

| Signal to Noise and Distortion (SINAD) Performance |           |
|--|-----------|
| Range  | SINAD, dB |
| ±10 V  | 84        |
| ±2.5 V   | 82        |
| ±500 mV  | 77        |

Calibrated and measured with a 10 kHz signal at 0.95 FSR, at the maximum sampling rate.

| Effective Number of Bits (ENOB) Performance |                    |
|---|--------------------|
| Range                                       | Typical ENOB, bits |
| ±10 V                                       | 14                 |
| ±2.5 V                                      | 13                 |
| ±500 mV                                     | 13                 |

Calibrated and measured with a 10 kHz signal at 0.95 FSR, at the maximum sampling rate.

| Spurious-Free Dynamic Range (SFDR) Performance |                  |
|--|------------------|
| Range  | Typical SFDR, dB |
| ±10 V  | 95               |
| ±2.5 V   | 95               |
| ±500 mV  | 95               |

SFDR is measured at the maximum sampling rate.

#### Analog Output (USB-1602HS-2AO and USB-1604HS-2AO)

**Number of channels:** Two, independent (DAC 0, DAC 1)  
**Resolution:** 16-bits  
**Output range:** ±10 V  
**Throughput:** Two channels, 1 MS/s each channel  
**Pacer sources:** Internal, external, slaved to analog input pacing; refer to [“Pacing Sources” on page 6](#) for details.  
**Monotonicity:** 16-bits  
**Glitch energy:** < 12 nV/s  
**Current output:** ±5 mA max  
**Output coupling:** DC  
**Power up state:** DACs clear to midscale, (0 V, ±20 mV)  
**Output noise:** 3 mV rms max  
**Settling time (to .01% FS):**  
 10 V output step, (RL=5 kΩ, CL=200 pf): 5 μs  
**Slew rate:** 10 V/μs  
**Gain error:** ±0.01% of FSR  
**Zero error:** ±0.0045 V max  
**INL:** < 2 LSBs  
**DNL:** < 1 LSB  
**Offset error drift:** ±10 ppm/°C  
**Gain error drift:** ±10 ppm/°C

#### Analog Input Calibration

**Recommended warm-up time:** 15 minutes min  
**Calibration methods:** Factory calibration and field calibration supported  
**System calibration interval:** 1 year  
**System calibration references:** +8.192 V, +2.048 V, +0.4096 V ±5 mV.  
 Actual measured values stored in EEPROM:  
**Tempco:** 5 ppm/°C max  
**Long term stability:** 30 ppm/1000 h

#### Digital Input

**Number of channels:** 16 inputs (DIN0-DIN15)  
**Digital type:** 3.3 V CMOS; 5 V tolerant  
**Digital input transfer rate (H/W paced)**  
**DIO-only operation:** Up to 8 MHz.  
**DIO and AI operations:**  
 USB-1602HS, USB-1602HS-2AO: 2 MHz  
 USB-1604HS, USB-1604HS-2AO: 1.33 MHz  
**Input high voltage:** 2.0 V min, 5.5 V max  
**Input low voltage:** 0.8 V max, 0 V min  
**Absolute maximum input voltage:** 15 V (power-on and power-off conditions)  
**DIN pacing:** Onboard or external clock (XAPCR)  
**Pacer sources:** Onboard A/D clock, XAPCR (SCCI connector), or EXT CLK (BNC connector.)  
**DIN trigger modes and sources:** See [“Trigger Sources” on page 6](#) for details.  
**Input pull-ups:** 100 kΩ; contact us for alternative options  
**Latency, software paced:** 115 ms, typical; system-dependant

#### Digital Output

**Number of channels:** 16 outputs (DOUT0-DOUT15)  
**Output rate**  
**No analog outputs enabled:** 8 MHz max  
**Analog outputs enabled:** 1 MHz max  
**Type:** 3.3 V CMOS  
**Output high voltage (IOH = –2.5 mA):** 2.4 V min, 3.4 V max  
**Output low voltage (IOL = 2.5 mA):** 0.4 V max, 0 V min  
**Output current:** 2.5 mA max per pin  
**DOUT pacing:** Onboard or external clock (XDPCR)



# USB-1602HS and USB-1604HS Series

## Specifications



**Pacer sources:** Internal, external, pacing slaved to analog input pacing; refer to “Pacing Sources” below for details.

**Power on and reset state:** Low

**Latency, software paced:** 115 ms, typ; system-dependant

### Trigger Sources

**Available trigger sources:** Analog input hardware, analog software trigger, external digital input, digital pattern, counter/totalizer

**Analog input (hardware) trigger source**

USB-1602HS, USB-1602HS-2AO: CH0 to CH1

USB-1604HS, USB-1604HS-2AO: CH0 to CH3

**Input signal range:** Entire span of selected voltage range; channel selectable.

**Trigger level:** Software-selectable, 12-bit resolution

**Hysteresis:** Software-selectable, 12-bit resolution

**Latency:** 1.25  $\mu$ s typ

**Accuracy:**  $\pm 2\%$  of reading,  $\pm 10$  mV offset max

**Analog software trigger source**

USB-1602HS, USB-1602HS-2AO: CH0 – CH1

USB-1604HS, USB-1604HS-2AO: CH0 – CH3

**Trigger range:** Anywhere within range of the trigger channel

**Trigger level:** Software-selectable, 16-bit resolution

**Latency:** One sample period max

**External digital input trigger source:** EXT TRIG (BNC connector), or DIG TRIG (SCSI connector)

**Input signal range:**  $-15$  V to  $+15$  V max

**Trigger level:** TTL level sensitive

**Minimum pulse width:** 50 ns high, 50 ns low

**Latency:** 100 ns max

**Digital pattern triggering source:** DIN0 to DIN15

16-bit pattern triggering on the digital port. Software-selectable for trigger on equal, not equal, above, or below a value. Individual bits can be masked for “don’t care” condition. Latency is one sample period, max.

**Counter/totalizer triggering source:** CTR0 to CTR3

Counter/totalizer inputs can trigger an acquisition. User can select to trigger on a frequency, or total counts that are equal/not equal, above/below a value, or within/outside of a window rising/falling edge. Latency is one sample period, max.

### Pacing Sources

**Pacer clocks (two):** Input pacer clock, output pacer clock

**Input pacer:** For pacing A/D, DIN and counter signals. Can be internally generated or externally supplied (XAPCR).

**Output pacer:** For pacing DAC, DOUT and timer/PWM signals. Can be internally generated or externally supplied (XDPCR).

**Input pacer clock sources (two):** Internal, external

**Internal clock (software-selectable):**

**Analog channels:**

USB-1602HS, USB-1602HS-2AO: 500 ns to 1000 s in 20.83 ns steps

USB-1604HS, USB-1604HS-2AO: 750 ns to 1000 s in 20.83 ns steps

**DIN and counter channels:** 125 ns to 100 s in 20.83 ns steps.

Can be configured to pace AO and/or DOUT channels.

**External clock, TTL level input (XAPCR):**

**Analog channels:**

USB-1602HS, USB-1602HS-2AO: Down to 500 ns min

USB-1604HS, USB-1604HS-2AO: Down to 750 ns min

**DIN and counter channels:** Down to 125 ns min

Can be configured to pace DAC and/or DOUT channels.

**Input pacer rate:** Internal or external, XAPCR source

**Analog rate:**

USB-1602HS, USB-1602HS-2AO: 2 MHz max

USB-1604HS, USB-1604HS-2AO: 1.33 MHz max

**Digital rate:**

No analog channels enabled: 8 MHz if no analog channels are enabled.

Analog channels enabled:

USB-1602HS, USB-1602HS-2AO: 2 MHz max

USB-1604HS, USB-1604HS-2AO: 1.33 MHz max

**Pacer input high voltage:** 2.0 V min, 5.5 V max

**Pacer input low voltage:** 0.8 V max, 0 V min

**Minimum pulse width:** 50 ns high, 50 ns low

**Output pacer clock sources (four):** Internal output pacer clock, (independent of input pacer clock), external output pacer clock (XDPCR), internal input pacing clock, and external input pacing clock (XAPCR)

**Output pacer rate:** Internal or external, XDPCR source.

**Analog rate:** 1.0 MHz max

**Digital rate**

**Analog outputs not enabled:** 8 MHz, if no analog outputs are enabled,

**Analog outputs enabled:** 1 MHz

**Internal pacer routed to BNC or SCSI connector**

**Output high voltage (IOH =  $-2.5$  mA):**

**Output low voltage (IOL =  $2.5$  mA):**

XAPCR or XDPCR: 2.4 V min, 0.4 V max

### Counter Input

**Number of channels:** 4 independent counters (CTR0, CTR1, CTR2, CTR03); may be configured as gated.

**Modes:** Counter, Period, Pulse width, Timing

**Counter mode options:** Totalize, Clear on Read, Rollover, Stop at top, 16-bit or 32-bit, any other channel can decrement the counter

**Period mode options:** Measure x1, x10, x100, or x1000 periods, 16-bit or 32-bit, 4 timebases (20.83 ns, 208.3 ns, 2.083  $\mu$ s, 20.83  $\mu$ s), any other channel can gate the period measurement

**Pulse width mode options:** 16-bit or 32-bit values, 4 time bases to choose from (20.83 ns, 208.3 ns, 2.083  $\mu$ s, 20.83  $\mu$ s), any other channel can gate the pulse width measurement

**Timing mode options:** 16-bit or 32-bit values, 4 time bases (20.83 ns, 208.3 ns, 2.083  $\mu$ s, 20.83  $\mu$ s)

**Resolution:** 16- or 32-bits

**Maximum input frequency:** 20 MHz

**Input type:** TTL, rising edge triggered

**Absolute maximum input voltage:** 15 V

**Debounce function** 16 selections, from 500 ns to 25.5 ms, positive or negative edge, glitch detect and/or debounce modes

**Required input current:**  $\pm 5$   $\mu$ A

**Minimum pulse width:** 25 ns high, 25 ns low

**Input high voltage:** 2.0 V min, 5.5 V max

**Input low voltage:** 0.8 V max, 0 V min

### Timer Output

**Number of channels:** TMR/PWM0, TMR/PWM1

**Effective frequency range:** 0.0112 Hz to 24 MHz

**Period resolution:** 20.83 ns

**Pulse width resolution:** 20.83 ns

**Output high voltage (IOH =  $-2.5$  mA):** 2.4 V min

**Output low voltage (IOL = 2.5 mA):** 0.4 V max

**Output current:** 2.5 mA max per pin

### Quadrature Decoders

**Number of decoders:** 3 (CTR4A, B, Z; CTR5 A, B, Z; CTR6 A, B, Z)

**Signals per decoder:** A, B and Z

**Resolution:** 16- or 32-bits

**Maximum frequency:** 6 MHz

**Minimum pulse width:** 25 ns high, 25 ns low

**Debounce function:** 16 selections, from 500 ns to 25.5 ms, positive or negative edge, glitch detect, and/or debounce modes

**Input high voltage:** 2.0 V min, 5.5 V max

**Input low voltage:** 0.8 V max, 0 V min

**Absolute maximum input voltage:** 15 V

### Power

**Supply current (continuous mode):** 1.5 A max

**+5V EXT output voltage range:** 4.75 V to 5.25 V

**Isolation (measurement system to PC):** 500 VDC min

**AC power adapter:** MCC part number PS-5V2AEPS

**Output voltage:** 5 V,  $\pm 5\%$

**Output power:** 10 watts

**Power jack configuration:** Two conductor, barrel

**Power jack barrel diameter:** 6.3 mm

**Power jack pin diameter:** 2.0 mm

**Power jack polarity:** Center positive

# USB-1602HS and USB-1604HS Series

## Ordering



### Environmental

**Operating temperature range:** 0 °C to 55 °C max

**Storage temperature range:** -40 °C to 85 °C max

**Humidity:** 0% to 90% non-condensing max

### Mechanical

**Dimensions (L × W × H):** 142.2 × 180.3 × 38.1 (5.6 × 7.1 × 1.5 in.)

**Weight:** 675 g (1.5 lbs)

## Ordering Information

| Part No.       | Description   |
|----------------|---|
| USB-1602HS     | 16-bit, high-speed 2 MS/s simultaneous sampling device with two analog inputs, four counters, two timers, and 32 DIO lines. Includes USB cable, external power supply, and MCC DAQ software CD.                         |
| USB-1602HS-2AO | 16-bit, high-speed 2 MS/s simultaneous sampling device with two analog inputs, two analog outputs, four counters, two timers, and 32 DIO lines. Includes USB cable, external power supply, and MCC DAQ software CD.     |
| USB-1604HS     | 16-bit, high-speed 1.33 MS/s simultaneous sampling device with four analog inputs, four counters, two timers, and 32 DIO lines. Includes USB cable, external power supply, and MCC DAQ software CD.                     |
| USB-1604HS-2AO | 16-bit, high-speed 1.33 MS/s simultaneous sampling device with four analog inputs, two analog outputs, four counters, two timers, and 32 DIO lines. Includes USB cable, external power supply, and MCC DAQ software CD. |

DASYLab

Icon-based data acquisition, graphics, control, and analysis software

## Accessories

| Part No.  | Description                                     |
|-----------|---|
| CA-68-3R  | 68-pin ribbon cable, 3 feet.                    |
| CA-68-3S  | 68-pin shielded round cable, 3 feet.            |
| CA-68-6S  | 68-pin shielded round cable, 6 feet.            |
| TB-102    | Termination board with screw terminals.         |
| RM-TB-100 | 19-inch rack mount kit for use with the TB-102. |

## Software also Available from MCC

| Part No.      | Description   |
|---------------|---|
| TracerDAQ Pro | Out-of-the-box virtual instrument suite with strip chart, oscilloscope, function generator, and rate generator – professional version |