

DT9800 Series

Isolated, Multifunction USB Data Acquisition Modules

The DT9800 Series is a family of low-cost, isolated, multifunction USB data acquisition modules. All DT9800 Series modules feature 16SE/8DI inputs with 12- or 16-bit resolution, up to 100 kS/s throughput, 16 digital I/O lines, 2 counter/timers, and optional 12- or 16-bit analog outputs.

Key Features

- **±500V galvanic isolation...** prevents ground loops, maximizes analog signal integrity, and protects the computer
- **Runs on USB power...** ideal for portable applications... no external power supply needed
- **16SE/8DI** analog input channels, 12 or 16-bit resolution
- **Fast sampling:** up to 100 kHz throughput
- **Analog output channels:** optional 12- or 16-bit
- **16 DIO**, two 16-bit C/T
- **Flexible acquisition modes for input operations:** single value, continuous, and triggered scan
- **Includes free QuickDAQ software** to get up and running quickly.

Analog Inputs

All DT9800 Series modules support 16 single-ended or pseudo-differential analog input channels or eight differential analog input channels. Software selectable gain settings of 1,2,4, and 8 provide effective input ranges of ±1.25 V, ±2.5 V, ±5 V, and ±10 V. On the DT9801 and DT9801, you can specify a unipolar range of 0 – 10V.

±500V Isolation Protects Your Data

Computers are susceptible to ground-spikes through any external port. These spikes can cause system crashes and may even cause permanent damage to the computer. The DT9800 Series modules feature 500 Volts of galvanic isolation to protect the computer from ground-spikes and to ensure a reliable stream of data.

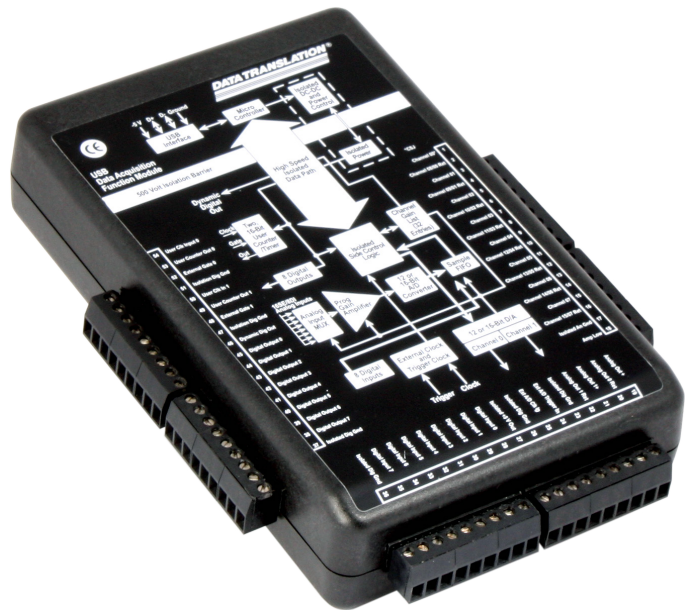

Figure 1. The DT9800 Series is a family of USB function modules for data acquisition.

Flexible Acquisition Modes... Using The Input Channel-Gain List

The DT9800 Series module can acquire data from one or more analog input channels using an input channel-gain list. A 32-location channel-gain list allows great flexibility in configuring channels, sample rates, and gains. For example, it permits sampling non-sequential analog input channels, analog input channels with different gains, and digital inputs at the A/D sample rate.

For each entry in the input channel-gain list, specify the channel to sample and the gain to apply to that channel. Channels in an input channel-gain list are sampled in order from the first entry to the last entry in the list. Channel numbering is zero-based; that is, the first entry in the input channel-gain list is entry 0, the second entry is entry 1, and so on.

Features Summary

Module	Analog Inputs				Analog Outputs				Digital I/O	
	Ch.	Resolution	Input Range	Throughput	Ch.	Resolution	Output Range	Output Speed	I/O Lines	Counter/Timer
DT9801	16SE/8DI	12 bits	±1.25V, ±2.5V, ±5V, ±10V 0-1.25V, 0-2.5V, 0-5V, 0-10V	100 kS/s	—	—	—	—	16	2
DT9802	16SE/8DI	12 bits	±1.25V, ±2.5V, ±5V, ±10V 0-1.25V, 0-2.5V, 0-5V, 0-10V	100 kS/s	2	12 bits	±5V, ±10V 0-5V, 0-10V	50 Hz	16	2
DT9803	16SE/8DI	16 bits	±1.25V, ±2.5V, ±5V, ±10V	100 kS/s	—	—	—	—	16	2
DT9804	16SE/8DI	16 bits	±1.25V, ±2.5V, ±5V, ±10V	100 kS/s	2	16 bits	±10V	50 Hz	16	2

The DT9800 Series modules provide two ways to cycle through the channel-gain list:

- **Continuous scan mode** — Choose this mode to accurately control the period between conversions of individual channels in the channel-gain list.
- **Triggered scan mode** — Choose this mode to accurately control both the period between conversions of individual channels in the channel-gain list and the period between each scan. This mode emulates a sample-and-hold function and is useful when synchronizing or controlling external equipment, or when acquiring a buffer of data on each trigger or retrigger.

Triggers

A trigger is an event that occurs based on a specified set of conditions. The DT9800 Series module supports the following trigger sources:

- **Software trigger** — A software trigger event occurs when you start the analog input operation (the computer issues a write to the module to begin conversions). Using software, specify the trigger source as a software trigger.
- **External trigger** — An external digital trigger event occurs when the DT9800 Series module detects a rising edge on the Ext A/D Trigger input signal connector. The trigger signal is TTL-compatible. Using software, specify the trigger source as an external, positive, digital (TTL) trigger.

Analog Output Channels

The DT9802 and DT9804 modules support two DC-level analog output channels (DAC0 and DAC1). Within each DAC, the digital data is double-buffered to prevent spurious outputs, then output as an analog signal. Both DACs power up to a value of 0 V \pm 10 mV. Resetting the module does not clear the values in the DACs. The DT9800 Series modules can perform single-value analog output operations only. Use software to specify the range, gain, and analog output channel, and then output the data from the specified channel. You cannot specify a clock source, trigger source, or buffer. Note: You cannot perform a single-value analog output operation while the A/D subsystem is running. The settling time for each DAC is 50 μ s (20 V steps). Single-value operations stop automatically when finished; you cannot stop a single-value operation.

Digital I/O

All DT9800 Series modules feature 16 digital I/O lines. These lines are divided into the following 8-bit ports: Port A, input and Port B, output. You can also read the status of Port A at rates as high as the maximum speed of the A/D by including the digital input lines of Port A as a channel in the analog channel-gain list. This dynamic digital input feature allows you to “time stamp” the digital inputs in relation to the analog inputs. In this mode, all 8 digital input lines of Port A are read as one word.

The digital outputs have sufficient current capability to drive external solid-state relay modules (sink 12 mA and source 1 mA). If you apply +5 V to the +5 V outputs, the digital outputs maintain their previous state if the computer goes down or if the USB cable is unplugged. On enumeration, the module senses +5 V and does not reset the digital outputs.

User Counter/Timers

Two 16-bit counter/timers are supported by all DT9800 Series modules. The counters are numbered 0 and 1. Each counter accepts a clock input signal and gate input signal and outputs a clock output signal (also called a pulse output signal). DT9800 Series modules support the following counter/timer operation modes: Event counting, Frequency measurement, Rate generation, One-shot, and Repetitive one-shot. You can cascade two counters internally through software or cascade more than two counters externally on the user connections. You can also set the duty cycle, frequency, and output polarity of the output pulse from the user counter/timers.

USB 2.0 Compatibility

The DT9800 Series modules are fully compatible with USB 2.0 and USB 1.1. USB 2.0 extends the speed of connection to up to 480 Mbps. For optimal performance, it is recommended that you use the modules with a USB 2.0 port. The DT9800 Series can be used with a USB 1.1 port, but at USB 1.1 performance. The DT9800 Series modules are USB powered... no external power supply needed.

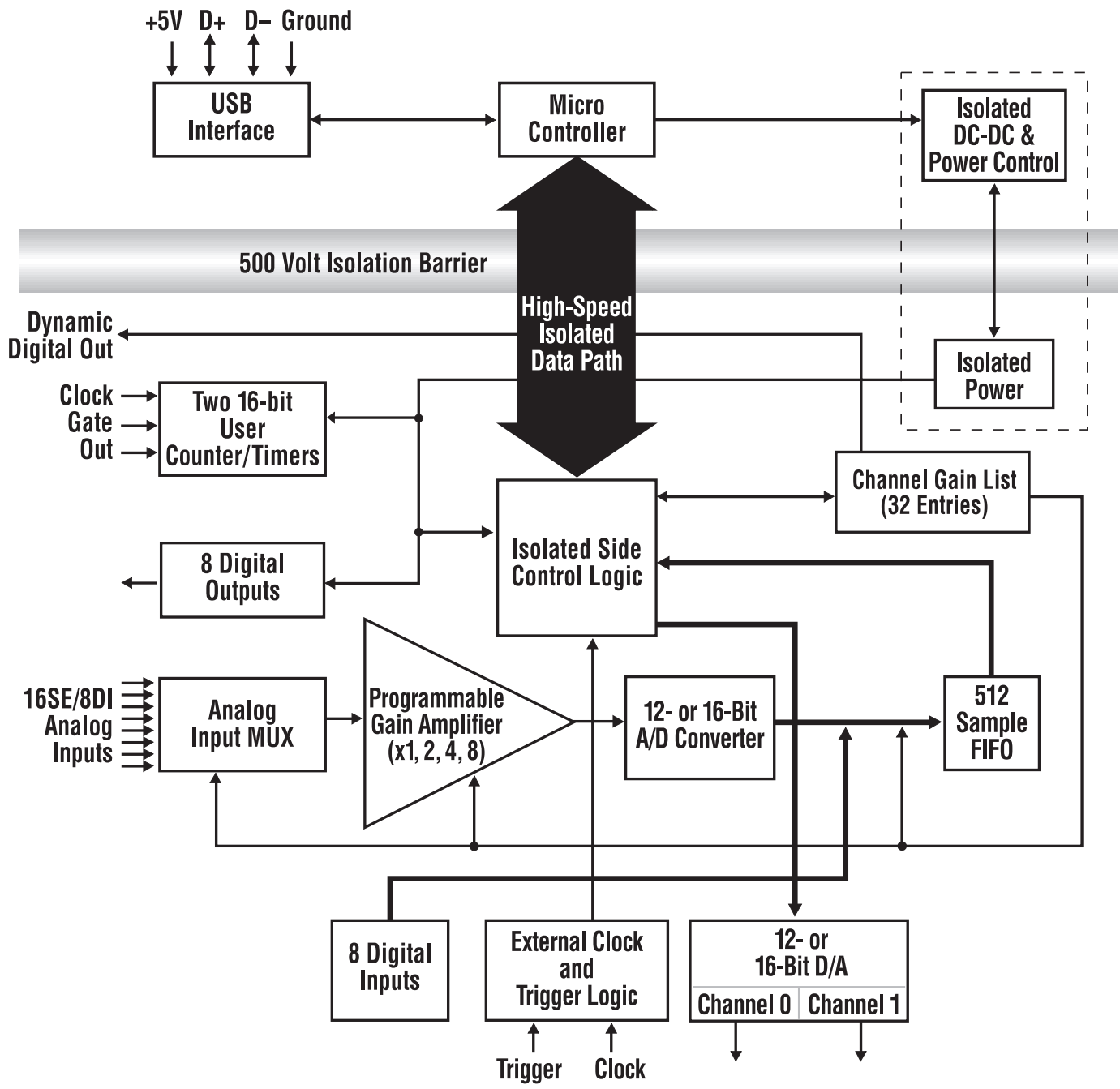

Figure 2: DT9800 Series Block Diagram

QuickDAQ

QuickDAQ allows you to acquire and display from all Data Translation USB and Ethernet data acquisition devices that support analog input streaming. Combine QuickDAQ with Data Translation hardware to acquire data, record data to disk, display the results in both a plot and digital display, and read a recorded data file. Be productive right out of the box with this powerful data logging software. Data can be exported to other applications like Microsoft Excel® and The Mathworks MATLAB® for more advanced analysis. Two additional options can be purchased to add FFT analysis capabilities to the base package.

Key Features:

- **QuickDAQ Base Package (Free)**
 - Ready-to-measure application software
 - Configure, acquire, log, display, and analyze your data
 - Customize many aspects of the acquisition, display, and recording functions to suit your needs
- **FFT Analysis Option (License Required)**
 - Includes all the features of the QuickDAQ Base Package
 - Perform single-channel FFT operations including:
 - ◆ Auto Spectrum
 - ◆ Spectrum
 - ◆ Power Spectral Density
 - Configure and view dynamic performance statistics
 - Supports Hanning, Hamming, Bartlett, Blackman, Blackman Harris, and Flat Top response windows
- **Advanced FFT Analysis Option (License Required)**
 - Includes all the features of the QuickDAQ Base Package and FFT Analysis Package
 - Perform 2-channel FFT operations including:
 - ◆ FRF
 - ◆ Cross-Spectrum
 - ◆ Cross Power Spectral Density
 - ◆ Coherence
 - ◆ Coherent Output Power
 - Supports real, imaginary, and Nyquist display functions
 - Additional FFT analysis functions supported: Exponential, Force, Cosiner Taper
 - Save data to .uff file format

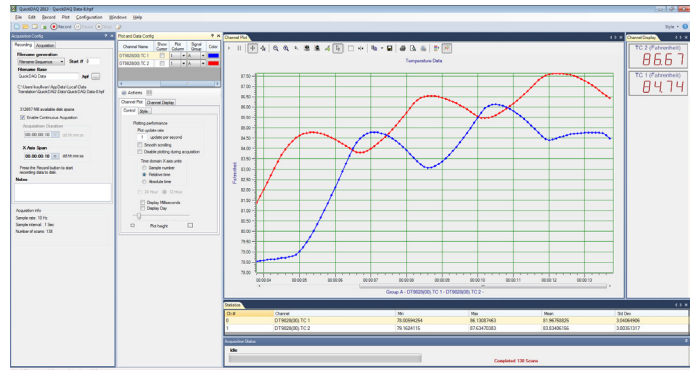

Figure 3: QuickDAQ ships free-of-charge and allows you to get up and running quickly.

Other Software Options

There are many software choices available for application development, from ready-to-measure applications to programming environments.

The following software is available for use with a DT9800 Series module and is provided on the Data Acquisition Omni CD:

- **Device Driver** – The device driver allows you to use a DT9800 Series module with any of the supported software packages or utilities.
- **Calibration Utility** – This utility allows you to calibrate features of a DT9800 Series module.
- **Quick DataAcq** application – The Quick DataAcq application provides a quick way to get up and running. Using this application, verify key features of the module, display data on the screen, and save data to disk.
- **DT-Open Layers® for .NET Class Library** – Use this class library if you want to use Visual C#® or Visual Basic® for .NET to develop application software using Visual Studio® 2003-2012; the class library complies with the DT-Open Layers standard.
- **DataAcq SDK** – Use the Data Acq SDK to use Visual Studio 6.0 and Microsoft® C or C++ to develop application software using Windows® XP/Vista/7/8; the DataAcq SDK complies with the DT-Open Layers standard.
- **DAQ Adaptor for MATLAB** – Data Translation's DAQ Adaptor provides an interface between the MATLAB® Data Acquisition (DAQ) toolbox from The MathWorks™ and Data Translation's DT-Open Layers architecture.
- **LV-Link** – Data Translation's LV-Link is a library of VIs that enable LabVIEW™ programmers to access the data acquisition features of DT-Open Layers compliant USB and PCI devices.

Cross-Series Compatibility

Virtually all Data Translation data acquisition modules are compatible with the DT-Open Layers® software standard. This means any application developed with one of Data Translation's software products can easily be upgraded to a new Data Translation module with little to no reprogramming needed.

Ordering Summary

HARDWARE:

- **DT9801** – USB function module with 12-bit, 100 kS/s analog inputs
- **DT9802** – USB function module with 12-bit, 100 kS/s analog inputs and two (2) 12-bit analog outputs
- **DT9803** – USB function module with 16-bit, 100 kS/s analog inputs
- **DT9804** – USB function module with 16-bit, 100 kS/s analog inputs and two (2) 16-bit analog outputs

ACCESSORIES:

- **DIN Rail Kit** – Kit for mounting modules to walls, cabinets, or machinery.

FREE SOFTWARE

- **QuickDAQ**
- **DAQ Adaptor for MATLAB** – Access the analyzation and visualization tools of MATLAB®.
- **LV-Link** – Access the power of Data Translation boards through LabVIEW™.

OPTIONAL SOFTWARE

- **QuickDAQ FFT Analysis Option** (License Required)
- **QuickDAQ Advanced FFT Analysis Option** (License Required)