

### Features

- 8-channel strain gage module
- 100% programmable; no pots to adjust
- Full, half, and quarter arm support
- 60 to 1000 Ohm bridge
- Software-selected Shunt-Cal
- Independent filter per channel
- Programmable excitation source
- Optional simultaneous sample and hold

The WBK16 is an 8-channel strain gage signal conditioning module for WaveBook systems. The WBK16 supports a wide range of bridge values configured for full, half, and quarter bridge configurations. Excitation voltage with remote sensing is supplied from an internal regulator, eliminating the need for an external voltage source. Also, one of two 4-pole filters can be selected via software, if desired. Up to eight WBK16s can be added to one WaveBook, enabling up to 64 channels of strain to be measured. For higher channel capacity, a multi-WaveBook system can be configured using the WaveBook/516E, for a maximum of 256 strain gage channels in one system.

In addition, the WBK16's wide gain ranges and filter selection (see below) make it an excellent general purpose or high gain amplifier for other transducer inputs.

All input signals are attached via eight DB9 connectors mounted on the front of the unit.

**Programmable Gain Amplifier.** Each of the WBK16's eight channels has an independent gain stage, software programmable in 86 steps from 1 to 20,000. This provides optimal gain for any strain application.

**Excitation Source.** The WBK16's excitation source is accurate to  $\pm 5$  mV with very low drift over time. The dual excitation sources are set through software for 0.5, 1, 2, 5, and 10 volt excitation, and can be used in either a standard or 6-wire Kelvin configuration. Each channel is individually current limited to 85 mA to protect against accidental shorts. In most applications, to eliminate the problems associated with bridge overheating, you will want to select the lowest possible excitation voltage which yields satisfactory results.



The WBK16 provides eight channels of strain gage input for the WaveBook

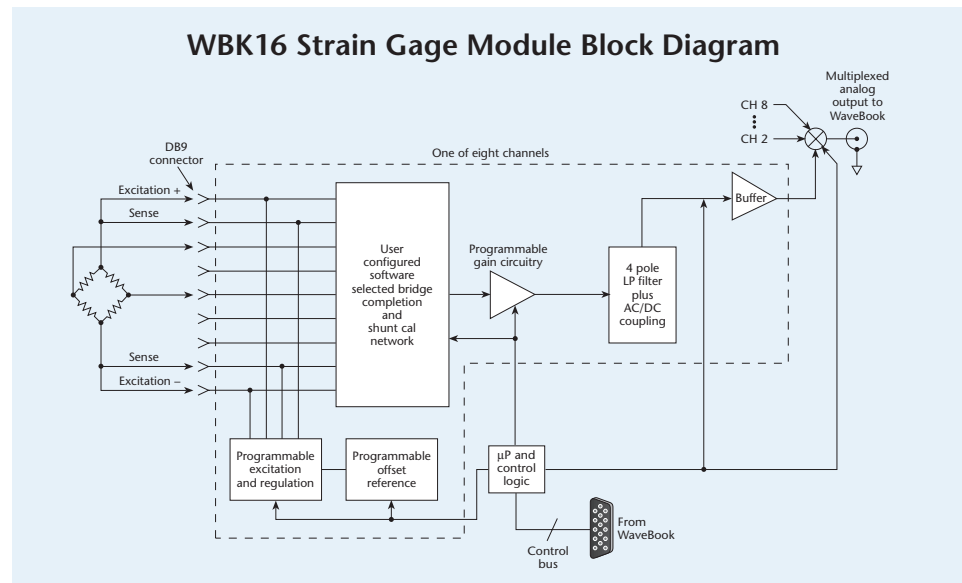

**Filtering.** Both high-pass AC coupling and low-pass noise rejection filtering can be enabled through software. Two 4-pole Butterworth filters factory-set to corner frequencies of 10 Hz or 1 kHz can be selected. The filters can be field modified over a range of 2 Hz to 20 kHz simply by inserting a user-supplied resistor pack.

**Ease of Configuration.** Unlike most strain modules with a single fixed configuration, the WBK16 allows multiple bridge configurations to be established, in advance, on a user-installed header. Once installed, each configuration can be selected through software at the time of operation. Depending on your configuration, there

may be no need to open the unit just because your transducer changes from full to quarter bridge or from 120 to 350 Ohm resistance. Simply change it in software. Each header supports two half bridge resistors, three quarter bridge values and three shunt cal values per channel.

**Shunt-Calibration.** The WBK16 features three user-installable, software-selected shunt-calibration resistors. This enables each channel to be put into a known imbalance condition to set or verify channel calibration. Shunt-cal allows a full scale gain to be set without physically loading the bridge to capacity.

# WBK16

## Specifications & Ordering Information



### Software

Gain adjustments, bridge balancing and other sensor calibration with the WBK16 is effortlessly handled with WaveView, IOtech's *Out-of-the-Box* software for WaveBook systems. The sensor calibration portion shown below enables a strain gage or transducer application to be easily configured, calibrated, and set up using an intuitive graphical user interface with guidance through the configuration and calibration.

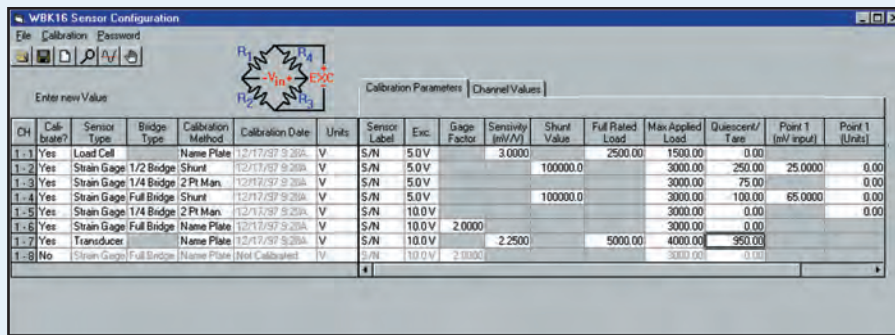

CN-189 and CN-115 header connectors provide bridge completion

**Filtering:** 4-pole Butterworth software selectable and factory set to 10 Hz, 1 kHz, or bypass; field changeable  
**Power Consumption:** 1.0A @ 15V (min)  
 1.7A @ 15V (max)

**Operating Temperature:** 0 to 50 °C  
**Storage Temperature:** 0 to 70 °C  
**Humidity:** 0 to 95% RH, non-condensing  
**Dimensions:** 285 mm W x 221 mm D x 45 mm H  
 (11" x 8.5" x 1.75")  
**Weight:** 1.32 kg (2.9 lbs)  
**Vibration:** MIL STD 810, category 1

**Auto Balance with Auto-zero.** Balancing the bridge is quick and convenient. No pots to adjust, LEDs to monitor, or dials to twist. Simply select the channels to auto balance and the WBK16 does the rest. Auto balance removes the static portion of the strain load and auto zeros the input to compensate for any input drift.

**Simultaneous Sampling.** The WBK16/SSH adds simultaneous sample and hold capability to all eight input channels. When multiple WBK16/SSH modules are installed, all channels on all modules sample within 100 ns of one another.

### Specifications

- Input Connector:** Standard female DB9 per channel.
- Channels:** 8
- Input:** Differential
- Input Impedance:** 100M Ohms
- Power Requirements:** 10 to 30 VDC or 120/240 VAC with included adapter
- Coupling:** AC and DC software selectable
- Accuracy:**
  - Offset Drift: 1µV RTI/ °C
  - CMRR @ DC to 60 Hz: 100 dB at gains > 100
- Cross Talk Rejection:** > 90 dB @ less than 1 kHz
- Bandwidth:**
  - 50 kHz @ gains <1 to 100
  - 10 kHz @ gains >100 to 2000
  - 1 kHz @ gains > 2000
- Bridge Configuration:**
  - Full Bridge (4 and 6 wire)
  - Half bridge
  - Quarter bridge (2 and 3 wire)
- Bridge Completion:** User supplied resistors on removable headers (included)
- Bridge Resistance:** 60 to 1000 Ohms
- Overall Gain:** 1 to 20,000, software selectable in 86 steps
- Shunt Calibration:** Software selection of 3 user supplied resistors
- Auto-Balance:** Selected per channel
- Auto-Calibration:** Either by actual measurement or calculated load
- Offset Adjustment:**
  - ±3V RTI @ gains 1 to 10
  - ±300 mV RTI @ gains 10 to 100
  - ±30 mV RTI @ gains 100 to 2000
  - ±3 mV @ 2000 to 20,000
- Excitation Source:** Two independent banks settable to 0.5V, 1V, 2V, 5V, 10V and off
- Excitation Accuracy:** ±5 mV
- Excitation Capacity:** 85 mA per channel with foldback current limiting

### Ordering Information

Description	Part No.
8-channel strain gage module, including AC adapter	WBK16
8-channel strain gage module with simultaneous sample and hold, including AC adapter	WBK16/SSH
Load cell shunt cal option for WBK16	WBK16/LC

### Accessories & Cables

Rack mount kit	RackDBK2
120 Ohm bridge resistor	BCR/120/1
350 Ohm bridge resistor	BCR/350/1
1000 Ohm bridge resistor	BCR/1000/1
Header connector	CN-115
Connector/adaptor DB9 to screw terminal	CN-189
5-pin male DIN to 5-pin male DIN provides convenient connection between WaveBook power input connectors and DBK30A (also used to daisy-chain input power to WBK expansion modules)	CA-115
5-pin DIN to automobile cigarette lighter power cable	CA-116

### Product Compatibility

- ✓ WaveBook