

# **PC104-DI48**

## User's Manual



Revision 3A  
September, 2000

## Trademark and Copyright Information

Measurement Computing Corporation, InstaCal, Universal Library, and the Measurement Computing logo are either trademarks or registered trademarks of Measurement Computing Corporation. Refer to the Copyrights & Trademarks section on [mccdaq.com/legal](http://mccdaq.com/legal) for more information about Measurement Computing trademarks. Other product and company names mentioned herein are trademarks or trade names of their respective companies.

© 2000 Measurement Computing Corporation. All rights reserved. No part of this publication may be reproduced, stored in a retrieval system, or transmitted, in any form by any means, electronic, mechanical, by photocopying, recording, or otherwise without the prior written permission of Measurement Computing Corporation.

### **Notice**

Measurement Computing Corporation does not authorize any Measurement Computing Corporation product for use in life support systems and/or devices without prior written consent from Measurement Computing Corporation. Life support devices/systems are devices or systems that, a) are intended for surgical implantation into the body, or b) support or sustain life and whose failure to perform can be reasonably expected to result in injury. Measurement Computing Corporation products are not designed with the components required, and are not subject to the testing required to ensure a level of reliability suitable for the treatment and diagnosis of people.

## Table of Contents

<b>1.0 INTRODUCTION</b>	1
<b>2.0 SOFTWARE INSTALLATION</b>	1
<b>3.0 HARDWARE INSTALLATION</b>	2
3.1 <i>BOARD SETUP</i>	2
3.2 <i>BASE ADDRESS</i>	2
<b>4.0 CABLING</b>	4
4.1 <i>INTRODUCTION</i>	4
4.2 <i>CONNECTOR DIAGRAM</i>	4
<b>5.0 DATA REGISTERS</b>	6
<b>6.0 SPECIFICATIONS</b>	7
<b>7.0 ELECTRONICS AND INTERFACING</b>	8
7.1 <i>UNCONNECTED INPUTS FLOAT</i>	8
7.2 <i>TTL TO SOLID STATE RELAYS</i>	9
7.3 <i>VOLTAGE DIVIDERS</i>	9
7.4 <i>LOW PASS FILTERS DE-BOUNCE INPUTS</i>	10

This page is blank.

## 1.0 INTRODUCTION

---

---

The PC104-DI48 is designed to have the best quality and lowest cost of any digital input board.

The PC104-DI48 conforms to the connector pin specification of all the PC104-DIO48 digital boards and CIO-Dxx48, 96 and 192 family digital boards, so may be used in place of one another without changing cabling or connectors.

These products are supported by Universal Library programming library.

## 2.0 SOFTWARE INSTALLATION

---

---

The board has a variety of switches and jumpers to set before installing the board in your computer. By far the simplest way to configure your board is to use the *InstaCal*<sup>™</sup> program provided as part of your software package. *InstaCal*<sup>™</sup> will show you all available options, how to configure the various switches and jumpers (as applicable) to match your application requirements, and will create a configuration file that your application software (and the Universal Library) will refer to so the software you use will automatically know the exact configuration of the board.

Please refer to the *Extended Software Installation Manual* regarding the installation and operation of *InstaCal*<sup>™</sup>. The following hard copy information is provided as a matter of completeness, and will allow you to set the hardware configuration of the board if you do not have immediate access to *InstaCal*<sup>™</sup> and/or your computer.

Details for setting of the switches are in the following section.

# 3.0 HARDWARE INSTALLATION

---

---

---

---

## 3.1 BOARD SETUP

The PC104-DI48 is setup at the factory with BASE ADDRESS= 300h (768 decimal).

Open your PC (after turning off the power) and install the board. Leave the address switches as they were set at the factory or refer to the information below to change the settings. After the board is installed and the computer is closed up, turn power on.

PC104-DI48 is a dedicated 48 line digital input board built up of logic chips. There are no control registers. The input pins present a single LSTTL load.

---

---

## 3.2 BASE ADDRESS

The PC104-DI48 employs the PC bus for power, communications and data transfer. As such, it draws power from the PC, monitors the address lines and control signals and responds to it's I/O address. It receives and places data on eight data lines.

Base address is the most important user-selectable item of the PC104-DI48. The base address is the starting location that software reads from when communicating with the PC104-DI48. DIP switches (Figures 3-1 and 4-2) are used to set the base address (0). Each switch position corresponds to one of the PC bus address lines. By placing the switch down, the address decode logic adds that value to the base address.

A base address is constructed by calculating the HEX or decimal number which will be the address the board will respond to. For example, in Figure 3-1, switches 1 and 2 are down, all others are up.

Switch 1 = 200h (512d) and switch 2 = 100h (256d). Added together they equal 300h (768 decimal).

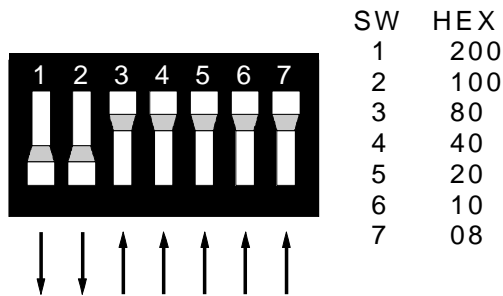

Figure 3-1. Base Address Switches (300h Shown)

Certain addresses are used by the PC, others are free and may be used by the PC104-DI48 and other expansion boards. We recommend that BASE = 300h (768D) be tried first. Refer to Table 3-1 below for PC I/O addresses.

Table 3-1. I/O Addresses

<b>HEX RANGE</b>	<b>FUNCTION</b>	<b>HEX RANGE</b>	<b>FUNCTION</b>
000-00F	8237 DMA #1	2C0-2CF	EGA
020-021	8259 PIC #1	2D0-2DF	EGA
040-043	8253 TIMER	2E0-2E7	GPIB (AT)
060-063	8255 PPI (XT)	2E8-2EF	SERIAL PORT
060-064	8742 CONTROLLER (AT)	2F8-2FF	SERIAL PORT
070-071	CMOS RAM & NMI MASK (AT)	300-30F	PROTOTYPE CARD
080-08F	DMA PAGE REGISTERS	310-31F	PROTOTYPE CARD
0A0-0A1	8259 PIC #2 (AT)	320-32F	HARD DISK (XT)
0A0-0AF	NMI MASK (XT)	378-37F	PARALLEL PRINTER
0C0-0DF	8237 #2 (AT)	380-38F	SDLC
0F0-0FF	80287 NUMERIC CO-P (AT)	3A0-3AF	SDLC
1F0-1FF	HARD DISK (AT)	3B0-3BB	MDA
200-20F	GAME CONTROL	3BC-3BF	PARALLEL PRINTER
210-21F	EXPANSION UNIT (XT)	3C0-3CF	EGA
238-23B	BUS MOUSE	3D0-3DF	CGA
23C-23F	ALT BUS MOUSE	3E8-3EF	SERIAL PORT
270-27F	PARALLEL PRINTER	3F0-3F7	FLOPPY DISK
2B0-2BF	EGA	3F8-3FF	SERIAL PORT

The PC104-DI48 BASE switch may be set for address in the range of 000-3FC so it should not be hard to find a free address area for you PC104-DI48. If you are not using IBM prototyping cards or some other board which occupies these addresses, then 300-31F HEX are free to use.

Addresses not specifically listed, such as 390-39F, are not reserved and may be available. Check your computer for other boards which may use I/O addresses.

## 4.0 CABLING

### 4.1 INTRODUCTION

The PC104-DI48 connector is a standard 50 pin header connector (Figure 4-2). A cable with mating connectors (C50FF-#) can be purchased from Measurement Computing Corporation.

### 4.2 CONNECTOR DIAGRAM

The PC104-DI48 connector is a 50-pin header-type connector.

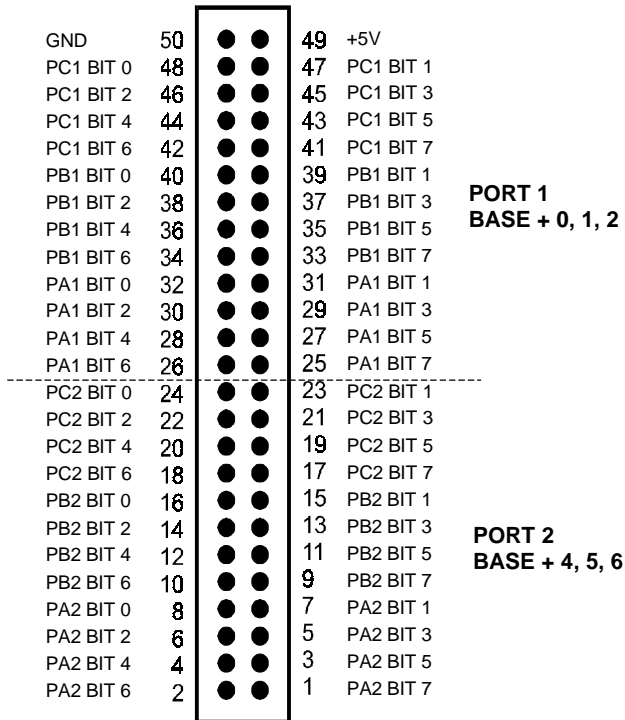

Figure 4-1. 50-Pin Connector



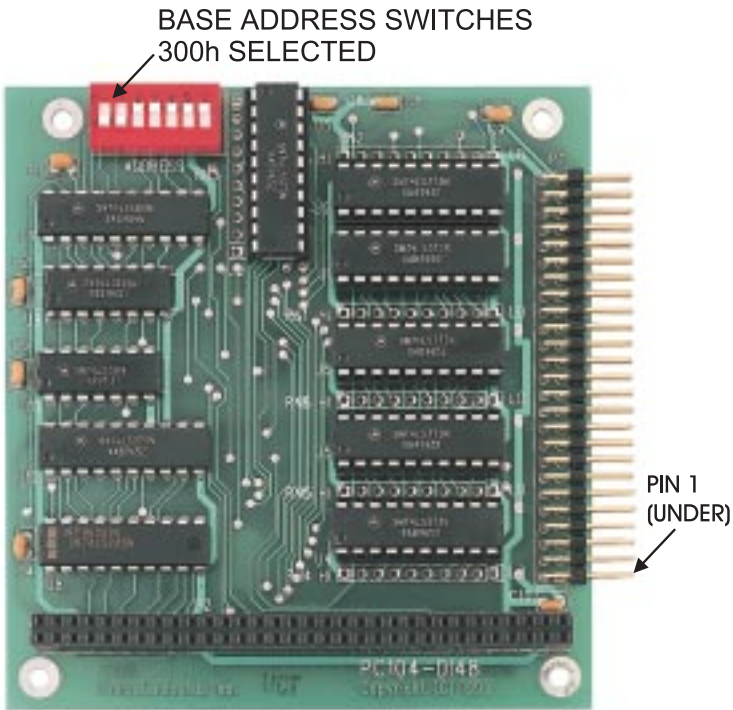

Figure 4-2. Base Address Switches and Pin 1 Locations

## 5.0 DATA REGISTERS

---

---

Each PC104-DI48 is composed of parallel input chips. Each address has one input buffer that senses eight input pins. The ports are arranged in sets of three, with an intervening N/A (not used) address area. This scheme allows compatibility with software written to control 82C55 based boards when the 82C55 is used as all inputs. (On those boards every fourth address contains a control register.)

The first address, or BASE ADDRESS, is determined by setting the base address switches on the board. To read data from an input register, a byte is read representing the status of all eight digital input lines. The individual bits are decoded as a (0) or a (1). Data read from registers must be analyzed to determine which bits are on or off.

The registers and their function are listed on the following table. Each register has eight bits of data.

ADDRESS	READ FUNCTION	WRITE FUNCTION
BASE + 0	Port 1A Data	None
BASE + 1	Port 1B Data	None
BASE + 2	Port 1C Data	None
BASE + 3	None	
BASE + 4	Port 2A Data	None
BASE + 5	Port 2B Data	None
BASE + 6	Port 2C Data	None
BASE + 7	None	

### PORTS 1A and 2A DATA

BASE ADDRESS + 0, and +4

7	6	5	4	3	2	1	0
A7	A6	A5	A4	A3	A2	A1	A0

### PORTS 1B and 2B DATA

BASE ADDRESS + 1, and +5

7	6	5	4	3	2	1	0
B7	B6	B5	B4	B3	B2	B1	B0

### PORTS 1C and 2C DATA

BASE ADDRESS + 2, and +6

7	6	5	4	3	2	1	0
C7	C6	C5	C4	C3	C2	C1	C0

## 6.0 SPECIFICATIONS

---

---

### POWER CONSUMPTION

+5V Supply	250 mA typical / 325 mA max.
+12V Supply	None.
-12V Supply	None.

### DIGITAL INPUT

Digital Type	Input: 74LS373
Configuration	6 banks of 8 bits each, input only
Number of channels	48 inputs
Input High	2.0 volts min, 7 volts absolute max
Input Low	0.8 volts max, -0.5 volts absolute min
Miscellaneous	Locations provided for installation of pull-up or pull-down resistors.

### ENVIRONMENTAL

Operating Temperature	0 to 70°C
Storage Temperature	-40 to 100°C
Humidity	0 to 90% non-condensing

## 7.0 ELECTRONICS AND INTERFACING

---

---

This short introduction to the electronics, most often needed by digital I/O board users, covers a few key concepts.

---

---

### 7.1 UNCONNECTED INPUTS FLOAT

Unconnected inputs will float. If you are using the PC104-DI48 board for input, and have unconnected inputs, ignore the data from those lines.

For example, if you connect bit A0 and not bit A1, do not be surprised if A1 stays low, stays high or tracks A0... It is unconnected and so is unspecified. The input buffer is not malfunctioning. In the absence of a pull-up/pull-down resistor, any input to a PC104-DI48 which is unconnected, is unspecified.

You do not have to tie input lines, and unconnected lines will not affect the performance of connected lines. Just make sure that you mask out any unconnected bits in software.

An alternative to masking inputs is to define the state of unused inputs by using pull-up or pull-down resistors. There are locations on the board for installation of these resistors marked RN1 through RN6. The location associated with FIRST PORT A (the port at Base +0) is RN1. The location for FIRST PORT B (the port at Base +1) is RN2. FIRST PORT C (Base +2) is RN3; SECOND PORT A (Base +4) is RN4; SECOND PORT B (Base +5) is RN5; SECOND PORT C (Base +6) is RN6.

A 10Kohm, eight-resistor SIP has all its resistors connected on one end to a single common pin. The common pin is marked with a dot and is at one end of the SIP. The other ends connect to eight in-line pins.

The SIP can be installed to pull-up or pull-down. At each location there are 10 holes in a line. One end of the line is marked HI; the other end LO. The eight holes in the middle are connected to the eight lines of a port, A, B, or C.

To pull-up lines, orient the SIP with the common pin (dot) in toward the HI end; to pull-down, install the resistor with the common pin in the LO hole.

Carefully solder the SIP in place.

A resistor value of 10K is recommended. Use other values only if you have determined the necessity for doing so.

---

---

## 7.2 TTL TO SOLID STATE RELAYS

Many applications require digital inputs monitor AC and DC voltages. High AC and DC voltages cannot be applied directly by the TTL digital lines.

Solid State Relays, such as those available from Measurement Computing Corp. allow control and monitoring of high AC and DC voltages and provide 400V isolation. Solid State Relays (SSRs) are recommended for interfacing to high voltages.

The most convenient way to use solid state relays is to purchase a Solid State Relay Rack. SSR Racks are available from Measurement Computing Corp.

---

---

## 7.3 VOLTAGE DIVIDERS

An alternative method of measuring a signal which varies over a range greater than the input range of a digital input, is to use a voltage divider. When correctly designed, it can drop the voltage of the input signal to a safe level the digital input can accept.

Ohm's law states:

$$\text{Voltage} = \text{Current} \times \text{Resistance}$$

Kirkoff's law states:

The sum of the voltage drops around a circuit will be equal to the voltage drop for the entire circuit.

In a voltage divider, the voltage across one resistor in a series circuit is proportional to the total resistance divided by the one resistor (see formula below).

The object in a voltage divider is to choose two resistors having the proportions of the maximum voltage of the input signal to the maximum allowed input voltage.

The formula for attenuation is:

$$\text{Attenuation} = \frac{R1 + R2}{R2}$$

$$2 = \frac{10K + 10K}{10K}$$

$$R1 = (A-1) \times R2$$

For example, if the signal varies between 0 and 20 volts and you wish to measure that with an analog input with a full scale range of 0 to 10 volts, the attenuation (A) is 2:1 or just 2.

For a given attenuation, pick a resistor and call it R2, the use this formula to calculate R1.

Digital inputs often require the use of voltage dividers. For example, if you wish to measure a digital signal that is at 0 volts when off and 24 volts when on, you cannot connect that directly to a digital input. The voltage must be dropped to 5 volts max when on. The attenuation is 24:5 or 4.8.

Using the equation above, if R2 is 1K,  $R_1 = (4.8-1) \times 1000 = 3.8K$ .

Remember that a TTL input is 'on' when the input voltage is greater than 2.5 volts.

#### NOTE

The resistors, R1 and R2, are going to dissipate power in the divider circuit according to the equation  $W = I^2 \times R$ ; (Current (I) = Voltage/Resistance). The higher the value of the resistance (R1 + R2), the less power dissipated by the divider circuit. Here is a simple rule:

For attenuation of  $<5:1$ , no resistor should be less than 10K.

For attenuation of  $> 5:1$ , no resistor should be less than 1K.

---

---

## 7.4 LOW PASS FILTERS DE-BOUNCE INPUTS

A low pass filter is placed on the signal wires between a signal and an A/D board. It prevents frequencies greater than the cut-off frequency from entering the A/D board's digital inputs.

The cut-off frequency is that frequency above which no variation of voltage with respect to time may enter the circuit. For example, if a low-pass filter had a cut-off frequency of 30 Hz, the kind of interference associated with line voltage (60 Hz) would be mostly filtered out but a signal of 25 Hz would pass with less attenuation.

Also, in a digital circuit, a low-pass filter is often used to remove contact bounce noise signals from a switch or a relay contacts.

A simple low-pass filter can be constructed from one resistor (R) and one capacitor (C). The cut-off frequency is determined according to the formula:

$$F_c = \frac{1}{2 \pi R C}$$

Where  $\pi = 3.14\dots$

R = ohms

C = farads

$$R = \frac{1}{2\pi C F_c}$$

Fc = cut-off frequency in cycles/second.

## EC Declaration of Conformity

We, Measurement Computing Corp., declare under sole responsibility that the product:

<u>Part Number</u>	<u>Description</u>
PC104-DI48	Digital input board

to which this declaration relates, meets the essential requirements, is in conformity with, and CE marking has been applied according to the relevant EC Directives listed below using the relevant section of the following EC standards and other normative documents:

**EU EMC Directive 89/336/EEC:** Essential requirements relating to electromagnetic compatibility.

**EU 55022 Class B:** Limits and methods of measurements of radio interference characteristics of information technology equipment.

**EN 50082-1:** EC generic immunity requirements.

**IEC 801-2:** Electrostatic discharge requirements for industrial process measurement and control equipment.

**IEC 801-3:** Radiated electromagnetic field requirements for industrial process measurements and control equipment.

**IEC 801-4:** Electrically fast transients for industrial process measurement and control equipment.

Carl Haapaoja, Director of Quality Assurance

**Measurement Computing Corporation**  
**10 Commerce Way**  
**Suite 1008**  
**Norton, Massachusetts 02766**  
**(508) 946-5100**  
**Fax: (508) 946-9500**  
**E-mail: [info@mccdaq.com](mailto:info@mccdaq.com)**  
**[www.mccdaq.com](http://www.mccdaq.com)**