

PC104-AC5

DIGITAL I/O

User's Manual



Revision 1A
October, 2000

Trademark and Copyright Information

Measurement Computing Corporation, InstaCal, Universal Library, and the Measurement Computing logo are either trademarks or registered trademarks of Measurement Computing Corporation. Refer to the Copyrights & Trademarks section on mccdaq.com/legal for more information about Measurement Computing trademarks. Other product and company names mentioned herein are trademarks or trade names of their respective companies.

© 2000 Measurement Computing Corporation. All rights reserved. No part of this publication may be reproduced, stored in a retrieval system, or transmitted, in any form by any means, electronic, mechanical, by photocopying, recording, or otherwise without the prior written permission of Measurement Computing Corporation.

Notice

Measurement Computing Corporation does not authorize any Measurement Computing Corporation product for use in life support systems and/or devices without prior written consent from Measurement Computing Corporation. Life support devices/systems are devices or systems that, a) are intended for surgical implantation into the body, or b) support or sustain life and whose failure to perform can be reasonably expected to result in injury. Measurement Computing Corporation products are not designed with the components required, and are not subject to the testing required to ensure a level of reliability suitable for the treatment and diagnosis of people.

"
"
"
"
"
"
"
"
"
"
"
"
"
"
"
"

Table of Contents

| | |
|---------------------------------------|----|
| 1 INTRODUCTION | 1 |
| 2 INSTALLATION | 1 |
| 2.1 BASE ADDRESS | 1 |
| 2.2 WAIT STATE SELECT (P3) | 3 |
| 2.3 IRQ IN/ +5V SELECT (P4) | 3 |
| 2.4 INTERRUPT LEVEL SELECT (P5) | 3 |
| 2.5 INSTALLING THE BOARD | 3 |
| 2.6 CONNECTOR DIAGRAM | 4 |
| 3 REGISTER ARCHITECTURE | 5 |
| 3.1 INTRODUCTION | 6 |
| 3.2 DIGITAL DATA REGISTERS | 7 |
| 3.3 CONTROL REGISTER | 8 |
| 4 SPECIFICATIONS | 10 |
| 5 ELECTRONICS AND INTERFACING | 12 |
| 5.1 INTRODUCTION | 12 |
| 5.2 PULL UP & PULL DOWN RESISTORS | 12 |
| 5.3 TTL TO SOLID STATE RELAYS | 14 |
| 5.4 VOLTAGE DIVIDERS | 14 |
| 5.5 LOW PASS FILTERS DE-BOUNCE INPUTS | 16 |

This page is blank.

1 INTRODUCTION

The PC104-AC5 is a 24-line digital I/O board. The control register which sets the direction of the I/O ports is identical to an 8255 in mode 0 (see 8255 data sheet). The I/O pins are high-drive TTL compatible.

The connector is a 50-pin header which is compatible with the pin-out of OPTO-22 and GORDOS solid state relay racks. If you are using an OPTO or GORDOS form factor solid state relay rack, the PC104-AC5 can be connected directly to the relay rack through a 50-pin cable such as the C50FE-2.

A group of application notes is included to assist in electrical interfacing.

2 INSTALLATION

Before you open your computer and install the board, install and run *InstaCal*, the installation, calibration and test utility included with your board. *InstaCal* will guide you through switch and jumper settings for your board. Detailed information regarding these settings can be found below. Refer to the *Extended Software Installation* manual for *InstaCal* installation instructions.

The PC104-AC5 has one bank of base address-select switches, an interrupt select jumper, a wait state select jumper and a jumper for configuring the function of pin 49 which must be set before installing the board in your computer.

2.1 BASE ADDRESS

On the base address switches, (Figure 2-1), each switch position corresponds to one of the PC bus address lines. By placing the switch down, the address decode logic responds to that address bit.

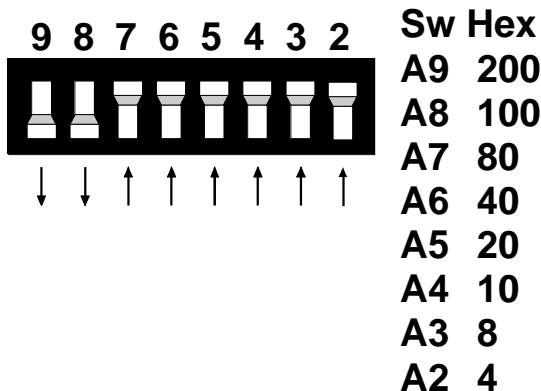

Figure 2-1. Base Address Switch - 300h Shown

A complete address is constructed by calculating the HEX or decimal number which corresponds to all the address bits the board has been instructed to respond to. For example, in Figure 2-1, switches 9 and 8 are DOWN, all others UP.

Using figure 2-1 as an example, address 9 = 200h (512D) and address 8 = 100h (256D); added together they equal 300h (768D).

Certain address are used by the PC, others are free and may be used by the PC104-AC5 and other expansion boards. We recommend BASE = 300h (768D) be tried first.

2.1.1 I/O Addresses

The BASE switch may be set for an address in the range of 000-3FC so it should not be hard to find a free address area for your board. If you are not using IBM prototyping cards or some other board which occupies these addresses, 300-31Fh are free to use. Refer to Table 2-1.

Addresses not specifically listed, such as 390-39Fh, are free.

Table 2-1. Computer I/O Addresses

| HEX RANGE | FUNCTION | HEX RANGE | FUNCTION |
|-----------|-------------------------------|-----------|------------------|
| 000-00F | 8237 DMA #1 | 2C0-2CF | EGA |
| 020-021 | 8259 PIC #1 | 2D0-2CF | EGA |
| 040-043 | 8253 TIMER | 2E0-2E7 | GPIB (AT) |
| 060-063 | 82C55 PPI (XT) | 2E8-2EF | SERIAL PORT |
| 060-064 | 8742 CONTROLLER (AT) | 2F8-2FF | SERIAL PORT |
| 070-071 | CMOS RAM & NMI MASK (AT) CARD | 300-30F | PROTOTYPE |
| 080-08F | DMA PAGE REGISTERS | 310-31F | PROTOTYPE CARD |
| 0A0-0A1 | 8259 PIC#2 | 320-32F | HARD DISK (XT) |
| 0A0-0AF | NMI MASK (XT) | 378-37F | PARALLEL PRINTER |
| 0C0-0DF | 8237 #2 (AT) | 380-38F | SDLC |
| 0F0-0FF | 80287 NUMERIC CO-P (AT) | 3A0-3AF | SDLC |
| 1F0-1FF | HARD DISK (AT) | 3B0-3BB | MDA |
| 200-20F | GAME CONTROL | 3BC-3BF | PARALLEL PRINTER |
| 210-21F | EXPANSION UNIT (XT) | 3C0-3CF | EGA |
| 238-23B | BUS MOUSE | 3D0-3DF | CGA |
| 23C-23F | ALT BUS MOUSE | 3E8-3EF | SERIAL PORT |
| 270-27F | PARALLEL PRINTER | 3F0-3F7 | FLOPPY DISK |
| 2B0-2BF | EGA | 3F8-3FF | SERIAL PORT |

2.2 WAIT STATE SELECT (P3)

A wait state may be enabled on the PC104-AC5 by selecting the ON position of header P3. Enabling the wait state decreases the PC's bus transfer rate during I/O reads or I/O writes to the PC104-AC5. The wait state may be necessary for situations where the PC's I/O transfer rate is too fast for the PC104-AC5, causing the board to randomly fail. If this is the case the jumper should be placed in the ON position. The factory default location is OFF.

2.3 IRQ IN/ +5V SELECT (P4)

The PC104-AC5's header P4 provides the option of routing either +5V or an externally generated interrupt to pin 49 of the 50-pin connector P1. The +5V option may be used in applications that require the PC104-AC5 to provide +5V power to accessory boards connected to P1. The IRQ position may be used for applications where an external interrupt needs to be passed to the PC104-AC5 which is then passed to PC. The particular interrupt level to be used can be selected using header P5 (see section 2.4).

CAUTION

Be sure to place jumper P4 in the correct position for your application. When the jumper is in the 5V position, it supplies 5VDC to pin 49. If pin 49 is connected to an external circuit that is not a 5VDC power input, it may damage the external circuit or this board.

2.4 INTERRUPT LEVEL SELECT (P5)

The interrupt jumper needs to be set only if the software you are using requires it. The PC104-AC5 provides interrupt levels 2 to 7 when using jumper-selectable header P5. If you do set the interrupt jumper to a value other than X (no interrupt), please check your PC's current configuration for possible interrupt conflicts. The factory default setting is no interrupt (P5, position X).

2.5 INSTALLING THE BOARD

1. Turn the power off.

2. Remove the cover of your computer. Please be careful not to dislodge any of the cables installed on the boards in your computer as you slide the cover off.
3. If desired, install plastic standoffs on board.
4. Install the board firmly in the extension jack.

2.6 CONNECTOR DIAGRAM

The PC104-AC5 I/O uses a 50-pin header-type connector. The signals available are direct connections to an 82C55 digital I/O integrated circuit. Figure 2-2 shows the pin outs for the connector.

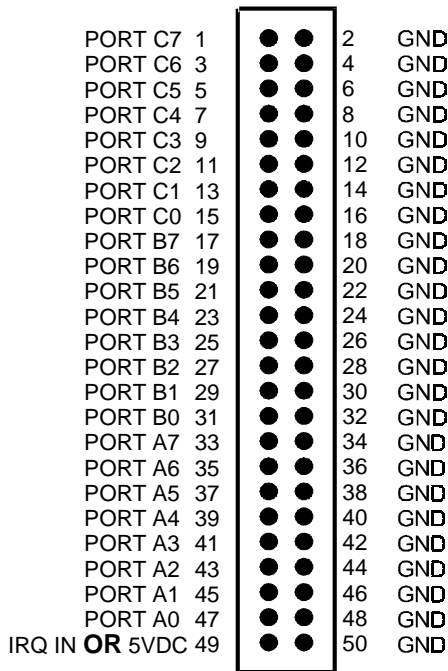

Figure 2-2. Digital Connector Pin Out

CAUTION

Be sure to place jumper P4 in the correct position for your application. When the jumper is in the 5V position, it supplies 5VDC to pin 49. If pin 49 is connected to an external circuit that is not a 5VDC power input, it may damage the external circuit or this board.

This board is typically used for driving the SSR-PB24 solid state relay rack. For this application, the C50FE-# cable is used.

If your application requires point to point wiring, you may want to consider the C50FF-# cable and a screw terminal board to simplify connections to the PC104-AC5. Please refer to the information on the CIO-TERM100, CIO-SPADE50 and CIO-MINI50 screw terminal boards or the SCB-50 and SCB-100 screw terminal boards and enclosure.

3 REGISTER ARCHITECTURE

3.1 INTRODUCTION

The PC104-AC5 contains three data and one control register for the 24 lines of digital I/O.

The first address, or BASE ADDRESS, is determined by setting a bank of switches on the board.

Register manipulation is best left to experienced programmers as most of the PC104-AC5 functions are implemented in the easy to use Universal Library.

The register descriptions follow all follow the format:

| | | | | | | | |
|----|----|----|----|----|----|----|----|
| 7 | 6 | 5 | 4 | 3 | 2 | 1 | 0 |
| A7 | A6 | A5 | A4 | A3 | A2 | A1 | A0 |

Where the numbers along the top row are the bit positions within the 8-bit byte and the numbers and symbols in the bottom row are the functions associated with that bit.

To write to or read from a register in decimal or HEX, the following weights apply:

| BIT POSITION | DECIMAL VALUE | HEX VALUE |
|---------------------|----------------------|------------------|
| 0 | 1 | 1 |
| 1 | 2 | 2 |
| 2 | 4 | 4 |
| 3 | 8 | 8 |
| 4 | 16 | 10 |
| 5 | 32 | 20 |
| 6 | 64 | 40 |
| 7 | 128 | 80 |

To write a control word or data to a register, the individual bits must be set to 0 or 1 then combined to form a byte.

The method of programming required to set/read bits from bytes is beyond the scope of this manual.

In summary form, the registers and their function are listed on the following table. Within each register are eight bits which may constitute a byte of data or eight individual bit set/read functions.

Table 3-1. Board Register Functions

| ADDRESS | READ FUNCTION | WRITE FUNCTION |
|---------|------------------|-------------------|
| BASE +0 | 1st Port A Input | 1st Port A Output |
| BASE +1 | 1st Port B Input | 1st Port B Output |
| BASE +2 | 1st Port C Input | 1st Port C Output |
| BASE +3 | None. | Configure I/O |

3.2 DIGITAL DATA REGISTERS

Port A

Base Address + 0

| | | | | | | | |
|----|----|----|----|----|----|----|----|
| 7 | 6 | 5 | 4 | 3 | 2 | 1 | 0 |
| A7 | A6 | A5 | A4 | A3 | A2 | A1 | A0 |

Port B Data

Base Address +1

| | | | | | | | |
|----|----|----|----|----|----|----|----|
| 7 | 6 | 5 | 4 | 3 | 2 | 1 | 0 |
| B7 | B6 | B5 | B4 | B3 | B2 | B1 | B0 |

Ports A & B may be programmed as input or output. Each is written to and read from in bytes, but for control and monitoring, use individual bits.

When using bit set/reset and bit read functions, unwanted bits must be masked out of reads and ORed into writes.

Port C Data

Base Address +2

| | | | | | | | |
|-----|-----|-----|-----|-----|-----|-----|-----|
| 7 | 6 | 5 | 4 | 3 | 2 | 1 | 0 |
| C7 | C6 | C5 | C4 | C3 | C2 | C1 | C0 |
| CH3 | CH2 | CH1 | CH0 | CL3 | CL2 | CL1 | CL0 |

Port C may be used as one 8-bit port of either input or output, or it may be split into two 4-bit ports which may be independently input or output. The notation for the upper 4-bit port is CH3 - CH0, and for the lower, CL3 - CL0.

Although it may be split, every read and write to port C carries eight bits of data so unwanted information must be ANDed out of reads, and writes must be ORed with the current status of the other port.

3.2.1 Output Ports

Ports configured for output hold the output data written to them. This output byte can be read back by reading a port configured for output.

IMPORTANT NOTE

THIS BOARD EMULATES THE 82C55. WHENEVER A 82C55 IS POWERED ON OR RESET, ALL PINS ARE SET TO HIGH IMPEDANCE INPUT. SO DOES OUR EMULATION.

The implications of this is that if you have output devices such as solid state relays, they may be switched on whenever the computer is powered on or reset. To prevent unwanted switching and to drive all outputs to a known state after power on or reset, pull all pins either high or low through a 10K resistor.

To install pull up/down resistor packs, see the application note.

3.2.2 Input Ports

In 82C55 mode 0 configuration, ports configured for input read the state of the input lines at the moment the read is executed, transitions are not latched.

3.3 CONTROL REGISTER

Configure A, B & C

Base Address +3

| | | | | | | | |
|---------|-----|-----|---|---------|-----|---|----|
| 7 | 6 | 5 | 4 | 3 | 2 | 1 | 0 |
| N/A | N/A | N/A | A | CU | N/A | B | CL |
| Group A | | | | Group B | | | |

The Ports A, B, C High and C Low may be independently programmed for input or output. The most commonly used mode for an 82C55 is mode 0, input / output mode. This is the only mode supported by the PC104-AC5. The codes for programming the emulated 82C55 in this mode are shown in Table 3-2.

NOTE: D7 is always 1 and D6, D5 & D2 are always 0.

Table 3-2. 82C55 Emulation Programming Codes - Mode 0

| D4 | D3 | D1 | D0 | HEX | DEC | A | CU | B | CL |
|-----------|-----------|-----------|-----------|------------|------------|----------|-----------|----------|-----------|
| 0 | 0 | 0 | 0 | 80 | 128 | OUT | OUT | OUT | OUT |
| 0 | 0 | 0 | 1 | 81 | 129 | OUT | OUT | OUT | IN |
| 0 | 0 | 1 | 0 | 82 | 130 | OUT | OUT | IN | OUT |
| 0 | 0 | 1 | 1 | 83 | 131 | OUT | OUT | IN | IN |
| 0 | 1 | 0 | 0 | 88 | 136 | OUT | IN | OUT | OUT |
| 0 | 1 | 0 | 1 | 89 | 137 | OUT | IN | OUT | IN |
| 0 | 1 | 1 | 0 | 8A | 138 | OUT | IN | IN | OUT |
| 0 | 1 | 1 | 1 | 8B | 139 | OUT | IN | IN | IN |
| 1 | 0 | 0 | 0 | 90 | 144 | IN | OUT | OUT | OUT |
| 1 | 0 | 0 | 1 | 91 | 145 | IN | OUT | OUT | IN |
| 1 | 0 | 1 | 0 | 92 | 146 | IN | OUT | IN | OUT |
| 1 | 0 | 1 | 1 | 93 | 147 | IN | OUT | IN | IN |
| 1 | 1 | 0 | 0 | 98 | 152 | IN | IN | OUT | OUT |
| 1 | 1 | 0 | 1 | 99 | 153 | IN | IN | OUT | IN |
| 1 | 1 | 1 | 0 | 9A | 154 | IN | IN | IN | OUT |
| 1 | 1 | 1 | 1 | 9B | 155 | IN | IN | IN | IN |

4 SPECIFICATIONS

Typical for 25°C unless otherwise specified.

Power consumption

+5V Operating

| | |
|-----------|----------------------------|
| PC104-AC5 | 625 mA typical, 960 mA max |
|-----------|----------------------------|

Digital Input / Output

| | |
|--------------------------------|--|
| Digital type | Digital Outputs - 74S244 Digital Inputs - 74LS373 |
| Number of I/O | 24 |
| Configuration | 2 banks of 8 bits each and 2 banks of 4 bits each (8255A mode 0 emulation) Each bank programmable as either input or output |
| Input low voltage | 0.8V max. |
| Input high voltage | 2.0V min. |
| Output low voltage | 0.5V max. (I _{ol} = 64 mA) |
| Output high voltage | 2.4V min. (I _{oh} = -15 mA) |
| High Level Output Current | -15 mA max. |
| Low Level Output Current | 64 mA max. |
| Absolute maximum input voltage | +5.5V max. |
| Pull-Up/Pull-Down Resistors | Locations provided for user-installation. |
| Power On / Reset | High impedance |

Interrupts

| | |
|--------------------------|--------------------------------------|
| Interrupt Source | External |
| Interrupt Levels | 2, 3, 4, 5, 6, 7 (jumper-selectable) |
| Interrupt enable/disable | Jumper-selectable (P4) |

Environmental

| | |
|-----------------------------|-------------------------|
| Operating Temperature Range | 0 to 70°C |
| Storage Temperature Range | -40 to 100°C |
| Humidity | 0 to 95% non-condensing |

Mechanical

| | |
|-----------------|-------------------------------------|
| Card dimensions | 103mm wide x 96mm long x 15mm thick |
|-----------------|-------------------------------------|

Connector and Pin Out

| | |
|-----------|--|
| Connector | 50-pin. Compatible with SSR-PB24 using C50FE-x cable |
|-----------|--|

| <i>Pin</i> | <i>Signal Name</i> | <i>Pin</i> | <i>Signal Name</i> |
|------------|--|------------|--------------------|
| 1 | PORT C – B7 | 2 | GND |
| 3 | PORT C – B6 | 4 | GND |
| 5 | PORT C – B5 | 6 | GND |
| 7 | PORT C – B4 | 8 | GND |
| 9 | PORT C – B3 | 10 | GND |
| 11 | PORT C – B2 | 12 | GND |
| 13 | PORT C – B1 | 14 | GND |
| 15 | PORT C – B0 | 16 | GND |
| 17 | PORT B – B7 | 18 | GND |
| 19 | PORT B – B6 | 20 | GND |
| 21 | PORT B – B5 | 22 | GND |
| 23 | PORT B – B4 | 24 | GND |
| 25 | PORT B – B3 | 26 | GND |
| 27 | PORT B – B2 | 28 | GND |
| 29 | PORT B – B1 | 20 | GND |
| 31 | PORT B – B0 | 32 | GND |
| 33 | PORT A – B7 | 34 | GND |
| 35 | PORT A – B6 | 36 | GND |
| 37 | PORT A – B5 | 38 | GND |
| 39 | PORT A – B4 | 40 | GND |
| 41 | PORT A – B3 | 42 | GND |
| 43 | PORT A – B2 | 44 | GND |
| 45 | PORT A – B1 | 46 | GND |
| 47 | PORT A – B0 | 48 | GND |
| 49 | IRQ IN OR +5V Out (jumper-selectable) See CAUTION Page 4 | 50 | GND |

5 ELECTRONICS AND INTERFACING

5.1 INTRODUCTION

This short introduction to the electronics most often needed by digital I/O board users covers the following topics:

- Pull up/pull down resistors
- Transistors
- Power MOSFETs
- Solid State Relays
- Voltage Dividers
- Low Pass Filters for digital inputs
- Noise; sources and solutions

IMPORTANT NOTE

This board emulates the 82C55. WHENEVER THE 82C55 IS POWERED ON OR RESET, ALL PINS ARE SET TO HIGH IMPEDANCE INPUT.

The implications of this fact is that if you have output devices such as solid state relays, they may be switched on whenever the computer is powered on or reset. To prevent unwanted switching and to drive all outputs to a known state after power on or reset, pull all pins either high or low through a 2.2K resistor.

To install pull up/down resistor packs, see the application note.

5.2 PULL UP & PULL DOWN RESISTORS

This description deals with pull up/down resistors and the emulated 82C55 digital I/O.

Whenever the PC104-AC5 is powered on or reset, the control register is set to a known state. That state is mode 0, all ports are inputs.

When used as an output device to control other TTL input devices, the PC104-AC5 applies a voltage level of 0V for low and 2.5V to 5V for high.

The concept of voltage level of a PC104-AC5 in input mode is meaningless. Do not connect a volt meter to the floating input of an PC104-AC5. It will show you nothing of meaning. In input mode the PC104-AC5 is in 'high Z' or high impedance. If your PC104-AC5 was connected to another input chip (the device you were controlling), the inputs of that chip are left floating whenever the PC104-AC5 is in input mode.

If the inputs of the device you are controlling are left to float, they may float up or down. Which way they float is dependent on the characteristics of the circuit and the electrical environment; and is unpredictable. This is why it often appears that the PC104-AC5 has gone 'high' after power up. The result is that the controlled device gets turned on.

That is why you need pull up/down resistors.

Shown here is one PC104-AC5 digital output with a pull-up resistor attached.

The pull-up resistor provides a reference to +5V while its value of 2200 ohms allows only about 2 mA to flow through the circuit.

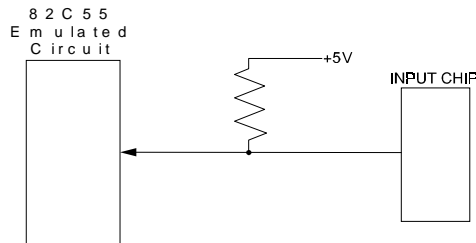

If the PC104-AC5 is reset and enters high impedance input, the line is pulled high. At that point, both the PC104-AC5 AND the device being controlled will sense a high signal.

If the PC104-AC5 is in output mode, the PC104-AC5 has more than enough power to over ride the pull-up/down resistor's high signal and drive the line to 0 volts. If the PC104-AC5 asserts a high signal, the pull up resistor guarantees that the line goes to +5V.

A pull-down resistor accomplishes the same task except that the line is pulled low when the PC104-AC5 is reset. The board has more than enough power to drive the line high.

The PC104-AC5 board is equipped with positions for pull-up/down resistors Single Inline Packages (SIPs). The positions are marked RN1 (Port A), RN2 (Port B) and RN3 (Port C) and are located beside the connector P1.

A 2.2Kohm, eight-resistor SIP has all its resistors connected on one end to a single common pin. The common pin is marked with a dot and is at one end of the SIP. The other resistor ends connect to eight in-line pins.

There are three locations for installation of SIP resistors on the PC104-AC5. They are marked RN1 through RN3. The SIP can be installed to pull-up or pull-down. At each location, RN1, 2, and 3, there are 10 holes in a line. On one end of the line a hole is marked HI; the other end LO. The eight holes in the middle are connected to the eight lines of a port, A, B, or C.

To pull-up all eight lines, orient the SIP with the common pin (dot) in the HI hole end; to pull-down, install the resistor with the common pin in the LO hole.

Carefully solder the SIP in place.

A 2.2K resistor SIP is recommended. Use other values only if you have calculated the necessity of doing so.

5.3 TTL TO SOLID STATE RELAYS

Many applications require digital outputs to switch AC and DC voltage motors on and off and to monitor AC and DC voltages. High voltages cannot be controlled or read directly by the TTL digital lines of a PC104-AC5.

Solid State Relays, such as those available from Measurement Computing Corp. allow control and monitoring of AC and high DC voltages and provide 750V isolation. Solid State Relays (SSRs) are the recommended method of interfacing to AC and high DC signals.

The most convenient way to use solid state relays and a PC104-AC5 board is to use a Solid State Relay Rack. A SSR Rack circuit board has output buffers to switch the socketed SSRs.

SSR Racks are available from Measurement Computing Corp.

5.4 VOLTAGE DIVIDERS

To measure a signal greater than the input range of a digital input, use a voltage divider to drop the voltage of the input to the level the board can safely accept.

In a voltage divider, the voltage across one of the resistors in a circuit is proportional to that resistance divided into the total resistance in the circuit.

The object is to choose two resistors with the proper ratio relative to the full scale of the digital input and the maximum signal voltage.

For dropping the voltage proportionally (attenuation) the formula for is:

$$\text{Attenuation} = \frac{R1+R2}{R2}$$

$$2 = \frac{10K+10K}{10K}$$

$$R1=(A-1)*R2$$

The variable *Attenuation* is the proportional difference between the signal voltage max and the full scale of the analog input.

For example, if the signal varies between 0 and 20 volts and you wish to measure that with an analog input with a full scale range of 0 to 10 volts, the *Attenuation* is 2:1 or just 2.

For a given attenuation, pick a handy resistor and call it R2, then use this formula to calculate R1.

Digital inputs also may require voltage dividers. For example, if you wish to input a 24 volt digital signal, you cannot connect that directly to the PC104-AC5 digital inputs. The voltage must be dropped to 5 volts max. The *Attenuation* is 24:5 or 4.8. Use the equation above to find an appropriate R1 if R2 is 1K. Remember that a TTL input is 'on' when the input voltage is greater than 2.5 volts.

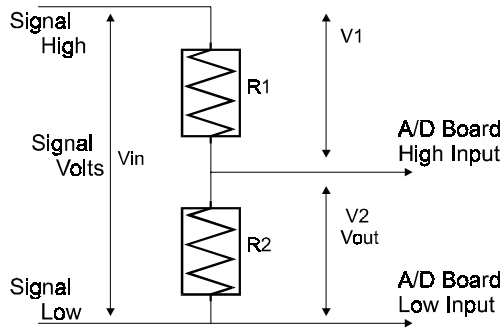

SIMPLE VOLTAGE DIVIDER - $V_{in} = \frac{R1+R2}{R2} V_{out}$

IMPORTANT NOTE

The resistors, R1 and R2, are going to dissipate all the power in the divider circuit according to the equation Current = Voltage / Resistance and power = current-squared times resistance. The higher the value of the resistance (R1 + R2) the less power dissipated by the divider circuit. Here is a simple rule:

For Attenuation of 5:1 or less, no resistor should be less than 10K.

For Attenuation of greater than 5:1, no resistor should be less than 1K.

The CIO-TERMINAL has the circuitry on board to create custom voltage dividers. It is a 16" by 4" screw terminal board with two 37-pin, D-type connectors and 56 screw terminals (12 - 22 AWG). Designed for table top, wall, or rack mounting, the board provides prototype, divider circuit, filter circuit and pull-up resistor positions which you can use for your application.

5.5 LOW PASS FILTERS DE-BOUNCE INPUTS

A low-pass filter between a signal source and an A/D board attenuates higher than the cut-off frequency, preventing them from entering the A/D board's analog or digital input circuits.

The key term in a low pass filter circuit is cut-off frequency. The cut-off frequency is that frequency above which no variation of voltage with respect to time may enter the circuit. For example, if a low pass filter had a cut-off frequency of 30 Hz, the kind of interference associated with line voltage (60 Hz) would be largely filtered out but a signal of 25 Hz would pass.

Low-pass filters are often used to remove a switch-bounce noise signal from a switch closure. The signal can be complex and have quite high frequency components requiring a more sophisticated filter.

A simple low-pass filter can be constructed from one resistor (R) and one capacitor (C). The cut off frequency is determined according to the formula:

$$F_c = \frac{1}{2 * \text{Pi} * R * C}$$

$$R = \frac{1}{2 * \text{Pi} * C * F_c}$$

Where Pi = 3.14...

R is in Ohms

C is in Farads

Fc is in cycles per second.

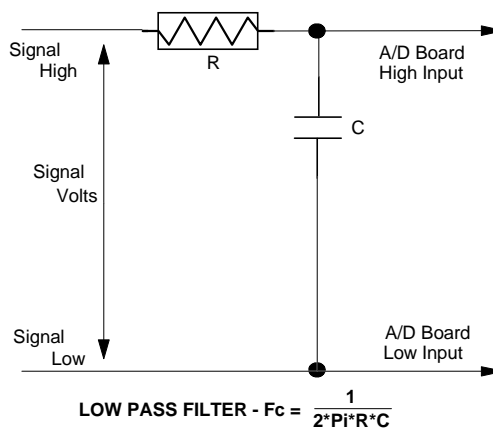

For your notes.

For your notes.

EC Declaration of Conformity

We, Measurement Computing Corp., declare under sole responsibility, that the product:

| | |
|------------------|--------------------------|
| <u>PC104-AC5</u> | <u>Digital I/O Board</u> |
| Part Number | Description |

to which this declaration relates, meets the essential requirements, is in conformity with, and CE marking has been applied according to the relevant EC Directives listed below using the relevant section of the following EC standards and other normative documents:

EU EMC Directive 89/336/EEC: Essential requirements relating to electromagnetic compatibility.

EU 55022 Class B: Limits and methods of measurements of radio interference characteristics of information technology equipment.

EN 50082-1: EC generic immunity requirements.

IEC 801-2: Electrostatic discharge requirements for industrial process measurement and control equipment.

IEC 801-3: Radiated electromagnetic field requirements for industrial process measurements and control equipment.

IEC 801-4: Electrically fast transients for industrial process measurement and control equipment.

Carl Haapaoja, Director of Quality Assurance

Measurement Computing Corporation
10 Commerce Way
Suite 1008
Norton, Massachusetts 02766
(508) 946-5100
Fax: (508) 946-9500
E-mail: info@mccdaq.com
www.mccdaq.com