

# BTH-1208LS

## Wireless Multifunction DAQ Device



The BTH-1208LS acquires wireless data acquisition at rates up to 1 kS/s and can be hosted by either a Windows-based or Android-based device.

### Overview

The BTH-1208LS offers Bluetooth communication in a multifunction DAQ device. When paired with a compatible Windows-based or Android-based host device, the BTH-1208LS offers short-range wireless communication of acquired data.

The BTH-1208LS offers analog I/O, digital I/O, and event counter input over either a wireless Bluetooth or physical USB connection.

### Bluetooth or USB Operation

The BTH-1208LS can operate wirelessly as a Bluetooth device or as a physically-connected USB device.

When operating as a Bluetooth device, the BTH-1208LS must be *paired* with the host device before it can wirelessly communicate acquired data. Pairing is a one-time procedure that establishes a bond with the host device.

The BTH-1208LS can transmit data up to 10 meters when operating as a Bluetooth device.

### Analog Input

The BTH-1208LS provides up to eight 11-bit SE analog inputs or four 12-bit DIFF analog inputs.

The device offers a fixed  $\pm 10$  V range for SE measurements, and  $\pm 20$  V,  $\pm 10$  V,  $\pm 5$  V,  $\pm 4$  V,  $\pm 2.5$  V,  $\pm 2.0$  V,  $\pm 1.25$  V, and  $\pm 1.0$  V ranges for DIFF measurements.

When performing a hardware-paced scan as a Bluetooth device, the BTH-1208LS supports a maximum aggregate sample rate of 1024 S/s. The total rate for all channels cannot exceed 1024 S/s.

The following table lists the per-channel sample rates (hardware paced) for one to eight channels in Bluetooth mode.

Maximum Per Channel Sample Rates (Bluetooth Mode – Hardware Paced)	
# of Channels in Acquisition	Maximum Sample Rate
1	1024 S/s
2	512 S/s
3	341.33 S/s
4	256 S/s
5	204.8 S/s
6	170.67 S/s
7	146.28 S/s
8	128 S/s

### Features

- Eight single-ended (SE) or four differential (DIFF) analog inputs
- Maximum Bluetooth® sample rates of 47 kS/s (BURSTIO) or 1 kS/s (hardware paced) over Bluetooth
- Maximum USB sample rates of 47 kS/s (hardware paced)
- Two 12-bit analog outputs
- Eight digital I/O and one 32-bit counter input
- Battery and USB power options

### Supported Operating Systems

- Windows 10/8/7/Vista®/XP 32/64-bit
- Android™

When operating in BURSTIO mode as a Bluetooth device, the BTH-1208LS can acquire data at a maximum aggregate rate of 47 kS/s. BURSTIO scans are limited to the depth of the onboard memory, as the data is acquired at a rate faster than it can be transferred to the computer.

When operating as a USB device, the device supports a maximum aggregate scan rate of 47 kS/s. The total acquisition rate for all channels cannot exceed 47 kS/s.

The following table lists the per-channel sample rates (hardware paced) for one to eight channels in USB mode.

Maximum Per Channel Sample Rates (USB Mode – Hardware Paced)	
# of Channels in Acquisition	Maximum Sample Rate
1	47 kS/s
2	23.5 kS/s
3	15.67 kS/s
4	11.75 kS/s
5	9.40 kS/s
6	7.83 kS/s
7	6.70 kS/s
8	5.88 kS/s

# BTH-1208LS

## Overview



### Channel-Gain Queue

The channel-gain queue feature lets you configure a list of channels and gains for each scan. Each channel can have a different gain setting. The gain settings are stored in a channel-gain queue list that is written to local memory on the device. The channel-gain queue list can contain up to 8 elements in SE mode or four elements in DIFF mode. The elements must be unique and listed in ascending order.

### Trigger Input

The BTH-1208LS external digital trigger input can be configured for either rising/falling edge, or high/low level.

### External Clock Input

An external clock signal connection is provided to pace input scanning operations.

### Analog Output

The BTH-1208LS includes two 12-bit analog outputs, each with an output range of 0 V to 2.5 V. The D/A is software paced, and throughput is system-dependent.

### Digital I/O

The BTH-1208LS supports up to eight digital I/O lines. When configured for input, the digital terminals can detect the state of any TTL-level input.

Digital input voltage ranges of up to 0 V to 5.5 V are permitted, with thresholds of 0.8 V (low) and 2.0 V (high).

Each DIO channel is an open-drain output which can sink up to 50 mA for direct drive applications when used as an output.

Inputs are pulled high by default to 3.3 V through 47.5 k $\Omega$  resistors on the circuit board. The pull-up voltage is common to all 47.5 k $\Omega$  resistors.

### Counter Input

The BTH-1208LS has a 32-bit event counter that can accept frequency inputs up to 1 MHz. The internal counter increments when the TTL levels transition from low to high.

### Power Options

When connected to a USB power supply, BTH-1208LS receives 5 V power. When the device is connected to a host USB port, USB provides both power and communication.

If rechargeable NiMH or NiCd batteries are installed, the batteries recharge when the device is connected to a USB host or USB power supply.

### Calibration

The BTH-1208LS is factory-calibrated using a NIST-traceable calibration process. Specifications are guaranteed for one year. For calibration beyond one year, return the device to the factory for recalibration.

### BTH-1208LS-OEM Version

The BTH-1208LS-OEM has a board-only form factor with header connectors for OEM and embedded applications (no case, CD, or network cable included). All devices can be further customized to meet customer needs.

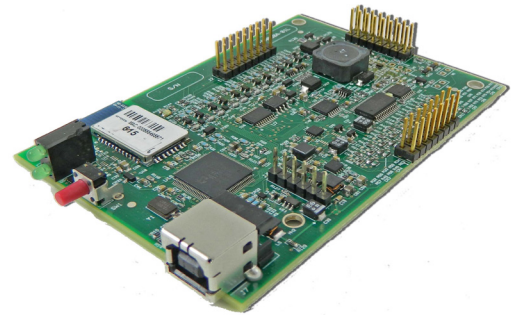

*The BTH-1208LS-OEM has the same specifications as the standard device, but in a board-only form factor with header connectors instead of screw terminals. In Bluetooth mode, power options from an external 5 V supply or a USB power supply are available.*

### Software Support

The BTH-1208LS is supported by the software in the table below.

#### Ready-to-Run Applications

[DAQami™](#)



Data acquisition companion software with drag-and-drop interface that is used to acquire, view, and log data, and generate signals. DAQami can be configured to log analog, digital, and counter channels, and to view that data in real-time or post-acquisition on user-configurable displays. Logged data can be exported for use in Excel® or MATLAB®. Windows OS

DAQami is included with the free MCC DAQ Software bundle (CD/download). Install DAQami and try the fully-functional software for 30 days. After 30 days, all features except for data logging and data export will continue to be available – data logging and data export features can be unlocked by purchasing the software.

[InstaCal™](#)

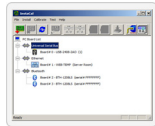

An interactive installation, configuration, and test utility for MCC hardware. Windows OS  
InstaCal is included with the free MCC DAQ Software bundle (CD/download).

[TracerDAQ® and  
TracerDAQ Pro](#)



Virtual strip chart, oscilloscope, function generator, and rate generator applications used to generate, acquire, analyze, display, and export data. Supported features may vary by hardware. The Pro version provides enhanced features. Windows OS

TracerDAQ is included with the free MCC DAQ Software bundle (CD/download).  
TracerDAQ Pro is available as a purchased software download.

#### General-Purpose Programming Support

[Universal Library™  
\(UL\)](#)

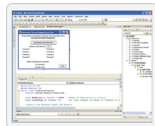

Library for developing applications in C, C++, VB, C# .Net, VB .Net, and Python. Windows OS

The UL is included with the free MCC DAQ Software bundle (CD/download).

[UL for Android™](#)



Programming library of Java classes for programmers who develop apps for Android-based tablets and phones. UL for Android communicates with select MCC DAQ devices. Supports Android project development on Windows, Linux, Mac OS X

UL for Android is included with the free MCC DAQ Software bundle (CD/download).

#### Application-Specific Programming Support

[ULx for  
NI LabVIEW™](#)

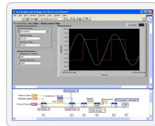

A comprehensive library of VIs and example programs for NI LabVIEW that is used to develop custom applications that interact with most MCC devices. Windows OS

ULx for NI LabVIEW is included with the free MCC DAQ Software bundle (CD/download).

[DASYLab®](#)



Icon-based data acquisition, graphics, control, and analysis software that allows users to create complex applications in minimal time without text-based programming. Windows OS

DASYLab is available as a purchased software download.

# BTH-1208LS

## Specifications

BTH-1208LS Block Diagram

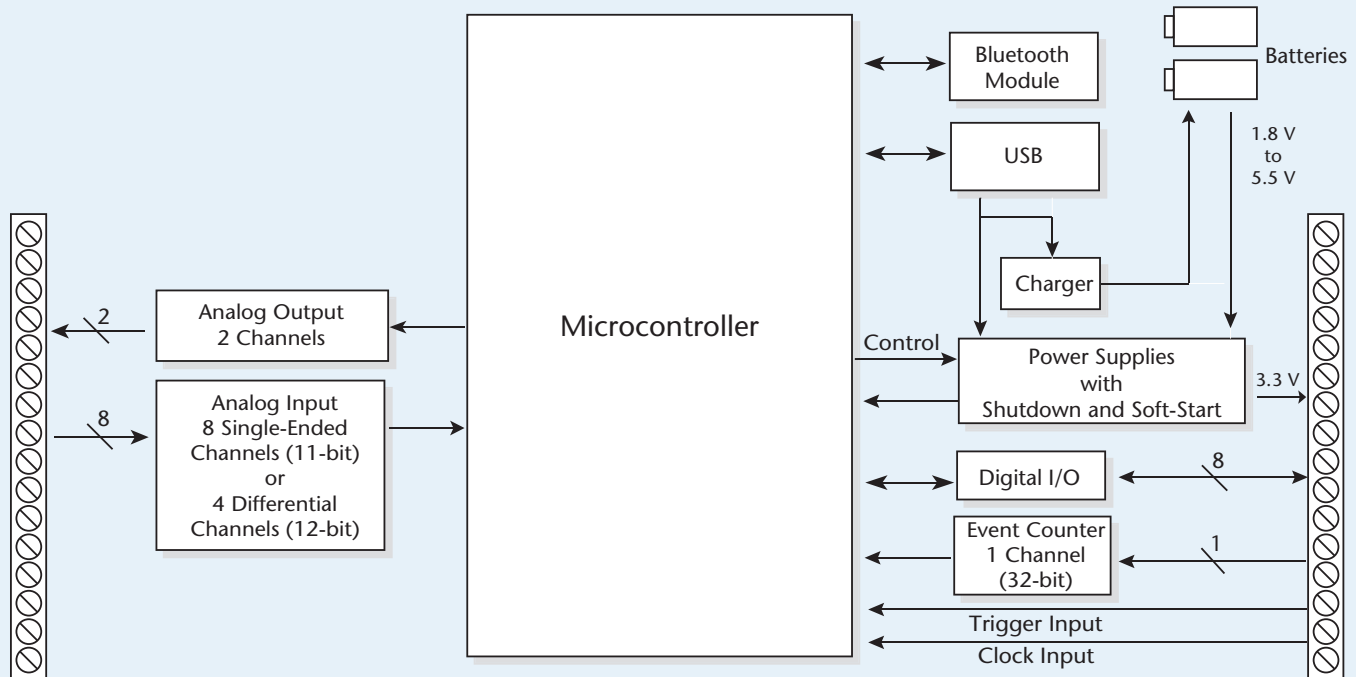

## Specifications

All specifications are subject to change without notice.  
Typical for 25°C unless otherwise specified.

### Analog Input

A/D converter type: Successive approximation type  
Input Voltage Range for Linear Operation (CHx to GND)

Single-ended mode:  $\pm 10$  V max

Differential mode:  $-10$  V min, 20 V max

Absolute maximum input voltage (CHx to GND):  $\pm 25$  V max

Input impedance: 140 k $\Omega$

Input current

$V_{in} = 10$  V: 70  $\mu$ A typ

$V_{in} = 0$  V:  $-12$   $\mu$ A typ

$V_{in} = -10$  V:  $-94$   $\mu$ A typ

Input current is a function of applied voltage on the analog input channels.  
For a given input voltage,  $V_{in}$ , the input leakage is approximately equal to  $(8.181 * V_{in} - 12)$   $\mu$ A.

Number of channels: 8 single-ended or 4 differential; software-selectable

Input ranges (software-selectable)

Single-ended:  $\pm 10$  V, G=2

Differential:  $\pm 20$  V, G=1;  $\pm 10$  V, G=2;  $\pm 5$  V, G=4;  $\pm 4$  V, G=5;  $\pm 2.5$  V, G=8;  $\pm 2.0$  V, G=10;  $\pm 1.25$  V, G=16;  $\pm 1.0$  V, G=20;

### Throughput

Maximum throughput when scanning is system-dependent

Software paced

10 S/s typ, system-dependent (Bluetooth)

250 S/s typ, system-dependent (USB)

Hardware paced

0.014 S/s to 1024 S/s (Bluetooth)

0.014 S/s to 47 kS/s (USB)

BURSTIO: 0.014 S/s to 47 kS/s to 12K (12,288) sample FIFO. Transfer rate to host is limited to 1024 S/s (Bluetooth)

Channel gain queue (software-selectable): 8 elements in SE mode, 4 elements in DIFF mode. One gain element per channel. Elements must be unique and listed in ascending order.

### Resolution

Differential: 12 bits, no missing codes

Single-ended: 11 bits (The AD7870 converter only returns 11 bits [0 to 2,047 codes] in single-ended mode)

Integral linearity error:  $\pm 1$  LSB typ

Differential linearity error:  $\pm 0.5$  LSB typ

Repeatability:  $\pm 1$  LSB typ

Trigger source (software-selectable): External digital (TRIG)

Pacer source (software-selectable)

Internal

External (AICKI), rising edge triggered

Analog Input Accuracy Differential Mode	
Range	Accuracy (LSB)
±20 V	5.1
±10 V	6.1
±5 V	8.1
±4 V	9.1
±2.5 V	12.1
±2 V	14.1
±1.25 V	20.1
±1 V	24.1
Single-Ended Mode	
±10 V	4.0

Analog Input Accuracy Components Differential Mode (All Values are (±))				
Range	% of Reading	Gain Error at Full Scale	Offset	Accuracy at Full Scale
±20 V	0.2	40 mV	9.766 mV	49.766 mV
±10 V	0.2	20 mV	9.766 mV	29.766 mV
±5 V	0.2	10 mV	9.766 mV	19.766 mV
±4 V	0.2	8 mV	9.766 mV	17.766 mV
±2.5 V	0.2	5 mV	9.766 mV	14.766 mV
±2 V	0.2	4 mV	9.766 mV	13.766 mV
±1.25 V	0.2	2.5 mV	9.766 mV	12.266 mV
±1 V	0.2	2 mV	9.766 mV	11.766 mV
Single-Ended Mode (All Values are (±))				
±10 V	0.2	20	19.531	39.531

Noise Performance Differential Mode		
Range	Typical Counts	LSBrms
±20 V	3	0.45
±10 V	3	0.45
±5 V	3	0.45
±4 V	4	0.61
±2.5 V	5	0.76
±2 V	7	1.06
±1.25 V	10	1.52
±1 V	12	1.82
Single-Ended Mode		
±10 V	6	0.91

### Analog Output

**Resolution:** 12-bits, 1 in 4,096

**Output range:** 0 V to 2.5 V

**Number of channels:** 2

**Throughput (software paced):** 10 S/s single channel typ, system-dependent  
Zero-scale offsets may result in a fixed zero-scale error producing a *dead-band* digital input code region. In this case, changes in digital input code at values less than 0x040 may not produce a corresponding change in the output voltage. The offset error is tested and specified at code 0x040.

**Power on and reset voltage**

**USB operation:** Initializes to 000h code

**Bluetooth operation:** The outputs can be individually configured to initialize to 000h or to have user-configurable values written to the outputs when the Bluetooth host device is connected or disconnected.

**Output current drive (each D/A OUT):** 5 mA source capability

**Slew rate:** 0.75 V/μs typ

### Analog Output Accuracy

All values are (±) accuracy tested at no load

Range: 0 V to 2.5 V

Accuracy (LSB): 8.0 typ, 73.0 max

### Analog Output Accuracy Components (All Values are (±))

Range: 0 V to 2.5 V

% of Reading: 0.16 typ, 1.44 max

Gain error at full scale: 4.0 mV typ, 36.0 mV max

Offset: 1.0 mV typ, 9.0 mV max

Zero-scale offsets may result in a fixed zero-scale error producing a *dead-band* digital input code region. In this case, changes in digital input code at values less than 0x040 may not produce a corresponding change in the output voltage. The offset error is tested and specified at code 0x040.

Accuracy at full scale: 5.0 mV typ, 45.0 mV max

### Digital Input/Output

**Digital type:** 3.3 V open drain

**Output value mapping**

0 written: Output drives to DGND

1 written: Output is pulled up to 3.3 V by internal resistor

**Number of I/O:** 8

**Configuration:** Individually configurable

**Input voltage range:** 0 V to 5.5 V

Each transistor source pin is internally connected to DGND

**Pull up/pull-down configuration:** 47.5 kΩ pull-up resistors (to 3.3 V), 2.2 kΩ series resistors

**Input high voltage threshold:** 2.0 V min

**Input high voltage limit:** 5.5 V absolute max

**Input low voltage threshold:** 0.8 V max

**Input Low voltage limit:** -0.5 V absolute min, 0 V recommended min

**Output Voltage range:** 0 V to 3.3 V (no external pull up resistor), 0 V to 5.5 V max

The external pull-up is connected to the digital output bit through an external pull-up resistor. Adding an external pull-up resistor connects it in parallel with the internal 47.5 kΩ pull-up resistor of that particular digital input/output bit. Careful consideration should be made when considering the external pull-up resistor value and the resultant pull-up voltage produced at the load.

**Output off state leakage current:** 1.0 μA typ

Does not include the additional leakage current contribution through the internal or any external pull-up resistor.

**Sink Current capability:** 50 mA max (continuous) per pin

**Transistor on resistance:** 0.7 Ω max

**Power on and reset state**

**USB operation:** All input

**Bluetooth operation:** The digital I/O can either be all input at power on / reset or may be configured to have user-configurable patterns written to the DIO when the Bluetooth host is connected or disconnected. Each transistor source pin is internally connected to DGND.

# BTH-1208LS

## Ordering



### External Trigger

**Trigger source:** External digital; TRIG terminal  
**Trigger mode:** Software configurable for edge or level sensitive, rising or falling edge, high or low level.  
**Trigger latency:** 10  $\mu$ s max  
**Trigger pulse width:** 1  $\mu$ s min  
**Input type:** Schmitt trigger, 47 k $\Omega$  pull-down to ground  
**Schmitt trigger hysteresis:** 0.76 V typ, 0.4 V min, 1.2 V max  
**Input high voltage threshold:** 1.74 V typ, 1.3 V min, 2.2 V max  
**Input high voltage limit:** 5.5 V absolute max  
**Input low voltage threshold:** 0.98 V typ, 0.6 V min, 1.5 V max  
**Input low voltage limit:** -0.5 V absolute min, 0 V recommended min

### External Clock Input

**Terminal name:** AICKI  
**Terminal type:** Input  
**Input clock rate:** 50 kHz, max  
**Clock pulse width:** 1  $\mu$ s min  
**Input type:** Schmitt trigger, 47 k $\Omega$  pull-down to ground  
**Schmitt trigger hysteresis:** 0.76 V typ, 0.4 V min, 1.2 V max  
**Input high voltage threshold:** 1.74 V typ, 1.3 V min, 2.2 V max  
**Input high voltage limit:** 5.5 V absolute max  
**Input low voltage threshold:** 0.98 V typ, 0.6 V min, 1.5 V max  
**Input low voltage limit:** -0.5 V absolute min, 0 V recommended min

### Counter

**Pin name:** CTR  
**Counter type:** Event counter  
**Number of channels:** 1  
**Input type:** Schmitt trigger, 47 k $\Omega$  pull-down to ground, rising edge triggered  
**Input source:** CTR screw terminal  
**Resolution:** 32 bits  
**Maximum input frequency:** 1 MHz  
**High pulse width:** 500 ns min  
**Low pulse width:** 500 ns min  
**Schmitt trigger hysteresis:** 0.76 V typ, 0.4 V min, 1.2 V max  
**Input high voltage threshold:** 1.74 V typ, 1.3 V min, 2.2 V max  
**Input high voltage limit:** 5.5 V absolute max  
**Input low voltage threshold:** 0.98 V typ, 0.6 V min, 1.5 V max  
**Input low voltage limit:** -0.5 V absolute min, 0 V recommended min

### Memory

**FIFO:** 12K (12,288) samples  
**Non-volatile EEPROM:** 2,048 bytes (768 bytes calibration, 256 bytes user, 1,024 bytes firmware use)

### Microcontroller

**Type:** High performance 16-bit RISC microcontroller

### Power

**Supply current, USB Source**  
**During enumeration:** < 100 mA  
**After USB enumeration or connected to USB charger/supply:** < 500 mA  
**Battery power:** Two AA cells; alkaline, NiCd, and NiMH cells supported  
**Battery charging:** NiMH and NiCd charging supported. Alkaline cells automatically detected and not charged.  
When operating from batteries, there is a user configurable power-off timer that will turn the device off when there is no host connection for the specified amount of time. The timer can be disabled or set to a value from 1 - 255 minutes.  
**+VO power available (after USB enumeration or Bluetooth connection):** 3.3 V nominal  
**+VO output current (after USB enumeration or Bluetooth connection):** 50 mA max

### Bluetooth

The Bluetooth radio is disabled when the device is connected to a USB host.  
**Device type:** Bluetooth 2.1  
**Device compatibility:** Backwards compatible with Bluetooth 2.0, 1.2, and 1.1  
**Bluetooth profile:** Serial Port Profile (SPP)  
**Radio range:** Class II, 10 m typ

### USB

**Device type:** USB 2.0 full speed  
**Device compatibility:** USB 1.1, USB 2.0

### Environmental

**Operating temperature range:** 0 °C to 50 °C (32 °F to 122 °F)  
**Storage temperature range:** -40 °C to 70 °C (-40 °F to 158 °F)  
**Humidity:** 0% to 90% non-condensing

### Mechanical

**Dimensions (L x W x H)**  
**BTH-1208LS:** 146.56 x 81.31 x 27.18 mm (5.77 x 3.28 x 1.07 in.)  
**BTH-1208LS-OEM (PCB dimensions):** 99.06 x 68.58 x 14.61 mm (3.90 x 2.70 x 0.58 in.)  
**USB cable length:** 3 m (9.84 ft) max  
**User connection length:** 3 m (9.84 ft) max

### Signal Connector

**Connector type**  
**BTH-1208LS:** Screw terminal  
**BTH-1208LS-OEM:** Three 2 x 8 pin, 0.1 in. pitch headers  
**Wire gauge range:** 16 AWG to 30 AWG

## Ordering Information

Part No.	Description
BTH-1208LS	Wireless DAQ device with 8 SE/4 DIFF analog inputs, 1 kS/s throughput in Bluetooth mode; 2 analog outputs; 8 digital I/O lines; and one 32-bit counter input channel
BTH-1208LS-OEM	Board-only wireless DAQ device with 8 SE/4 DIFF analog inputs, 1 kS/s throughput in Bluetooth mode; 2 analog outputs; 8 digital I/O lines; and one 32-bit counter input channel

## Accessories and Cables

Part No.	Description
ACC-205	DIN-rail kit; compatible with the BTH-1208LS standard device.

## Software also Available from MCC

Part No.	Description
DAQami	Data acquisition companion software for acquiring data and generating signals
TracerDAQ Pro	Out-of-the-box virtual instrument suite with strip chart, oscilloscope, function generator, and rate generator - professional version
DASyLab	Icon-based data acquisition, graphics, control, and analysis software